



genesis

connected solutions

SPECIFICATION FOR APPROVAL

CUSTOMER: _____

CUSTOMER PART NO: _____

PART NO: 230-10047-XX

DESCRIPTION: SlimSAS R/A SMT Connector

Genesis Connected Solutions
 1325 CAPITAL CIRCLE
 SUITE A
 LAWRENCEVILLE, GA 30043
 TEL: 404-874-4474
 Email: sales@genesis-connected.com
WWW.GENESIS-CONNECTED.COM

PROPRIETARY NOTICE This product specifications, herein, are the property Of Genesis Connected Solutions and shall not be reproduced or copied or used in whole or in part as the basis for manufacture or sale of items without written permission.	Size A	SPEC PART NUMBER: 230-10047-XX	Revision01	Page: 1 of 7
---	-----------	-----------------------------------	------------	--------------

PROPRIETARY INFORMATION
COMPANY CONFIDENTIAL

REV.	ECN. NO.	DESCRIPTION	ENG	DATE
X1		INITIAL	TERRY	05/31/18'
X2		ADD HOUSING COLOUR	LEO	10/01/22'

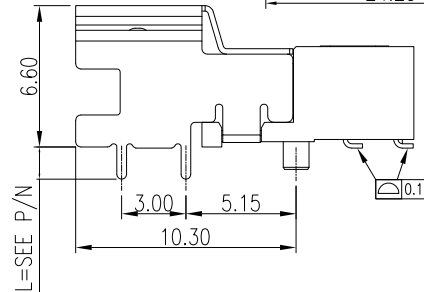
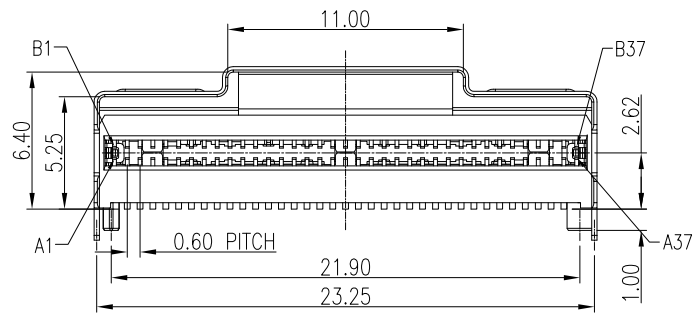
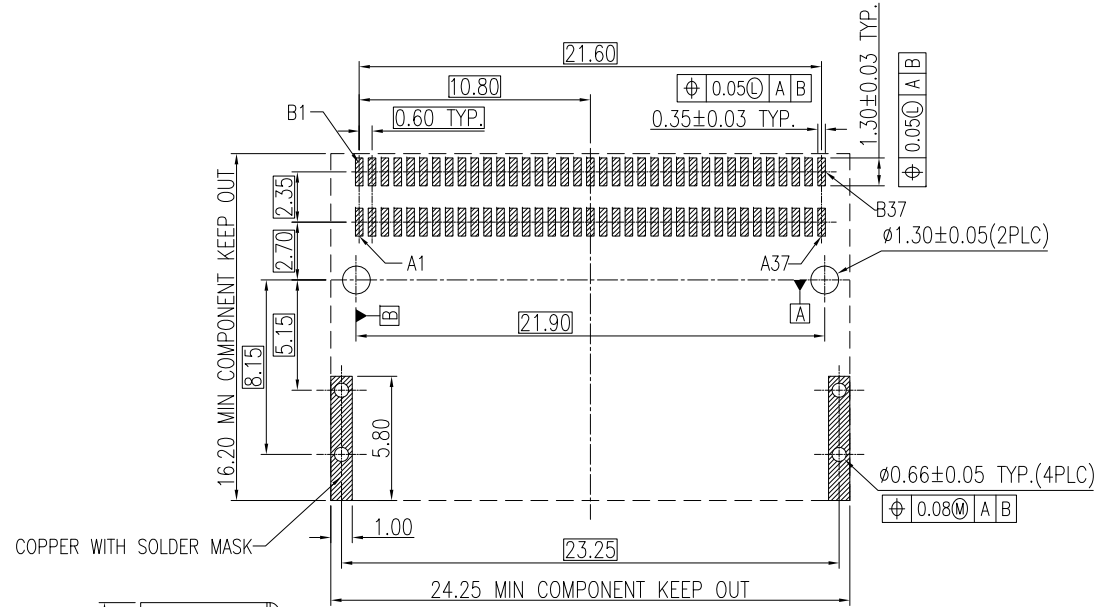
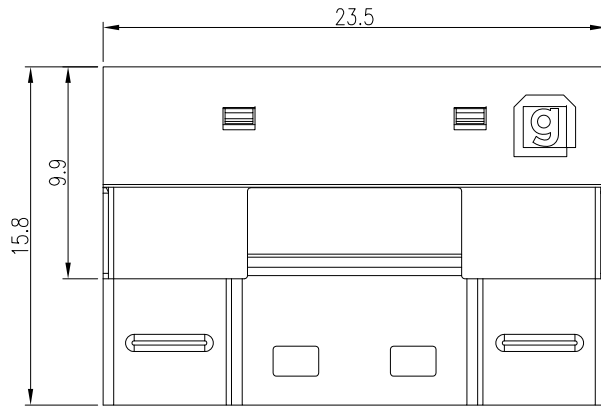

NOTES:

MATERIAL:

- 1: HOUSING: SOLDER REFLOW PROCESS COMPATIBLE LCP, BLACK, UL94V-0
- CONTACTS: HIGH PERFORMANCE COPPER ALLOY
- SHELL: SUS
- 2: ROHS COMPLIANT

PART NUMBER

PART NUMBER	GOLD PLATING	DIM. L
230-10047-01	GOLD 30u"	1.5mm
230-10047-02	GOLD 30u"	2.2mm
230-10047-03	GOLD 30u"	3.0mm
230-10047-04	GOLD 30u"	4.2mm
230-10047-05	GOLD 15u"	1.5mm
230-10047-06	GOLD 15u"	2.2mm
230-10047-07	GOLD 15u"	3.0mm
230-10047-08	GOLD 15u"	4.2mm

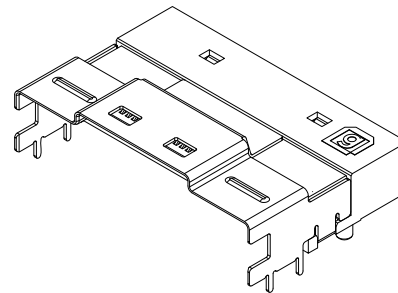
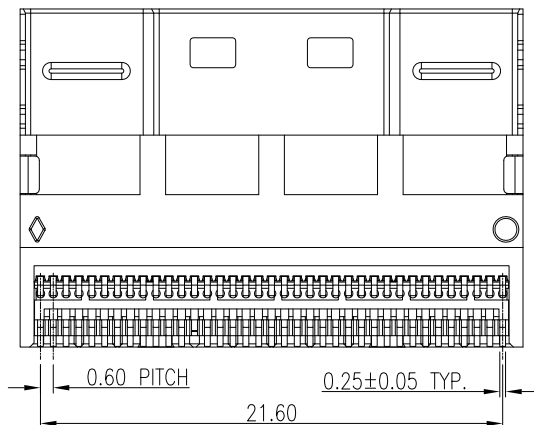

GENERAL TOLERANCE .X± .X±0.35 .XX±0.25 .XXX±0.15	ANGLE TOLERANCE X°± .X°± .XX°± .XXX°±	DRAWN Terry	DATE 5/31/18'		TITLE: SLIMSAS 8i R/A 85 ohm THRU PIN SHIELDED RECEPTACLE
MATL SEE BOM	FINISH SEE NOTES	CHECKED	DATE		PART NUMBER: 230-10047-XX
SCALE N/A	UNIT mm	APPROVED	DATE	DRAWING NO. 230-10047	SIZE A4 REV. X2
SHEET 1 OF 1					

Revision History:

GENESIS CONNECTED SOLUTIONS				
Date	Created By	Approved by	Revision	Description
09/23/2020	Terry		01	Initial release

1 SCOPE

This specification covers the performance requirements of the SlimSAS connector.
This document will be revised based on Connector drawing change or PCB land pattern change.

2 APPLICABLE DOCUMENT

These following documents form a part of this specification to this extent specified herein. In the event of conflict between the requirements of the specification and the product drawing, the product drawing shall take precedence. In the event of conflict between the requirements of this specification and the referenced documents, this specification shall take precedence.

Document Number	Description
UL 94	Rating V0
2002/95/EC	European Union Directive 2002/95/EC for the Restriction of Hazardous Substances (RoHS)
SAS-4	Serial Attached SCSI-4 INCITS 534
SFF-8654	0.6mm 4/8X Unshield I/O Connector
EIA-364	Environmental Test Methodology

3 REQUIREMENTS

3.1 DESIGN AND CONSTRUCTION

Product shall be of the design, construction and physical dimensions specified on the applicable product drawing 230-10047-XX

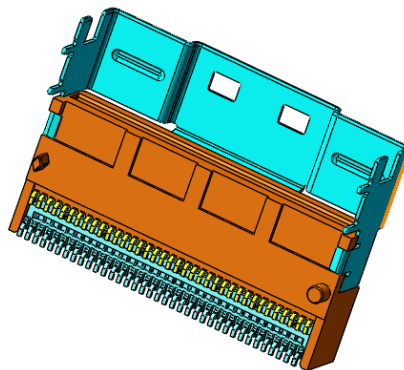

Figure 1

PROPRIETARY NOTICE This product specifications, herein, are the property Of Genesis Connected Solutions and shall not be reproduced or copied or used in whole or in part as the basis for manufacture or sale of items without written permission.	Size A	SPEC PART NUMBER: 230-10047-XX	Revision01	Page: 2 of 7
---	-----------	-----------------------------------	------------	--------------

PRODUCT SPECIFICATION

3.2 MATERIAL

Reference to engineering drawing.

3.3 OPERATING CONDITIONS

Table: 1

A	Current rating	0.5 A per contact
B	Voltage rating	30 V
C	Operating temperature	-20°C to +85°C
D	Humidity	80% RH MAX.

3.4 STORAGE CONDITIONS

Table: 2

A	Temperature	-20°C to +85°C
B	Humidity	80% RH MAX.

3.5 CONDITION OF REFLOW AND BY HAND

Hand solder: 350±10°C, 3±1 sec.

Reflow: Max 260°C 10sec, 230°C 60 sec (pre-heat at 130~180°C,60~120 sec)

Tested to profile shown below. Recommended to use fixture for soldering stability.

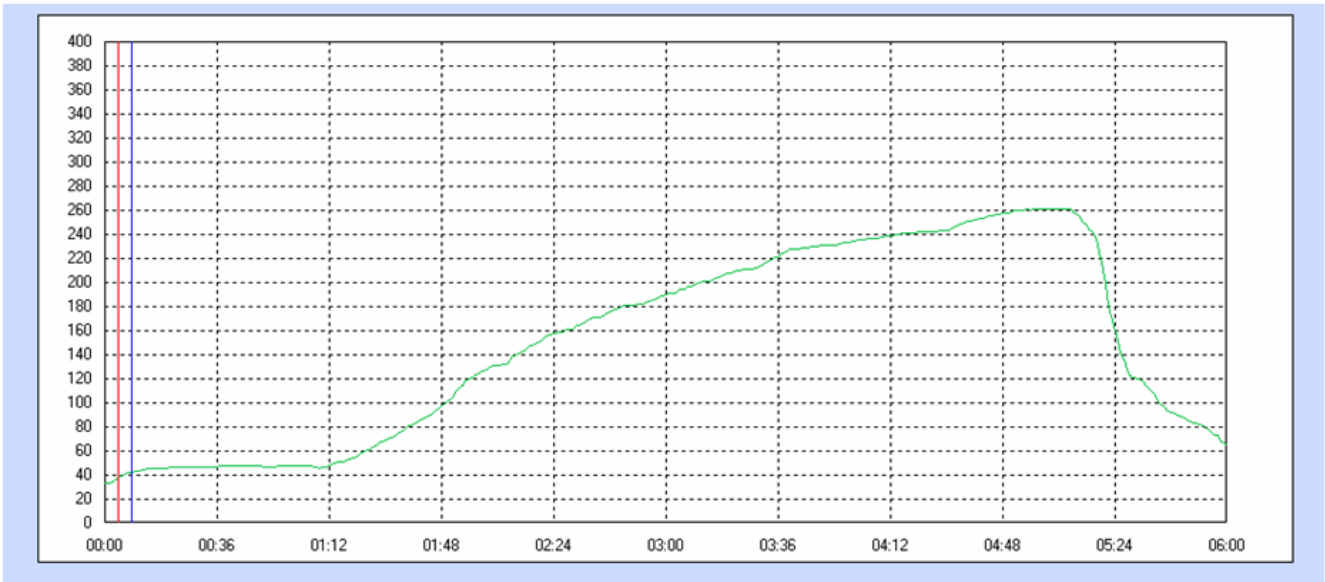

Figure 2 – Solder Reflow Profile

<p>PROPRIETARY NOTICE This product specifications, herein, are the property Of Genesis Connected Solutions and shall not be reproduced or copied or used in whole or in part as the basis for manufacture or sale of items without written permission.</p>	<p>Size A</p>	<p>SPEC PART NUMER: 230-10047-XX</p>	<p>Revision01</p>	<p>Page: 3 of 7</p>
---	-------------------	--	-------------------	---------------------

PRODUCT SPECIFICATION

3.6 TEST CONDITIONS

The product is designed to meet the electrical, mechanical and environmental performance requirements specified in Table 1.

3.7 ELECTRICAL PERFORMANCE

Parameter	Procedure	Requirement
Low level contact resistance(LLCR)	EIA 364-23 Subject mated contacts assembled in housing to 320mV DC. open circuit at 10mA.	Initial: 20mΩ maximum per contact
Insulation resistance	Measurements shall be made following application of DC 100V potential across terminals and across terminals and frame for 1 minute per EIA-364-21	1000MΩ minimum
Dielectric withstanding voltage	EIA 364-20 Test between adjacent contacts of mated and unmated connector assemblies.300 VDC for 1 minute.	No breakdown or flashover
Temperature Rise	Subject mated connectors to the rated current , per EIA-364-70	The temperature rise above ambient shall not exceed 30°C at any point in the connector when contact positions are powered.
Impedance	EIA-364-108, rise time 25ps	85Ω +/- 10%
SI	Per applicable industrial standard	Customer demand

3.9 MECHANICAL PERFORMANCE

Parameter	Procedure	Requirement
Durability	EIA 364-09 Perform 250 times of cycles at a maximum rate of 500 cycles per hour.	1: No physical damage. 2: 20 m Ω maximum change from initial
Durability (Preconditioning)	EIA 364-09 1.The test is as same as durability test. 2.Perform 50 times of cycles at a rate of 500 cycles per hour.	1: No physical damage.
Mating Force (with Latch disabled)	EIA 364-13 Measure force necessary to mate connector assemblies at Max. rate of 25.4 mm/min.	X4 : 21 N Max. X8 : 31 N Max
Un-mating Force (with Latch disabled)	EIA 364-13 Measure force necessary to mate connector assemblies at Max. rate of 25.4 mm/min.	X4 : 18 N Max. X8 : 24 N Max

<p>PROPRIETARY NOTICE This product specifications, herein, are the property Of Genesis Connected Solutions and shall not be reproduced or copied or used in whole or in part as the basis for manufacture or sale of items without written permission.</p>	Size	SPEC PART NUMBER:	Revision01	Page: 4 of 7
	A	230-10047-XX		

GENESIS CONNECTED SOLUTIONS**PRODUCT SPECIFICATION**

Active Latch retention strength	EIA 364-98 Pull cable 1 axis	No physical damage 50 N min. force
Normal force	Per EIA-364-04	35 g min/ contact

3.10 ENVIRONMENTAL PERFORMANCE

Parameter	Procedure	Requirement
Vibration	EIA 364-28 Condition II Test Subject mated connectors 30 minutes in each of three mutually perpendicular planes. (see note 2)	1: No discontinuities of 1 μ s longer duration. 2: No physical damage.
Physical shock	EIA 364-27 Condition A Subject mated connectors to 50 g's half-sine shock pulses of 11 msec duration. Three shocks in each direction applied along three mutually perpendicular planes for a total of 18 shocks.	1: No discontinuities of 1 μ s or longer duration. No physical damage.
Thermal shock	EIA 364-32 Test Condition 1. Subject mated connectors to 10 cycles between -55°C and +85°C	1: No physical damage. 2: 20 m Ω maximum change from initial
Humidity	EIA 364-31 Method II Test Condition B. Subject mated connectors to 240 hours at 40°C with 90% RH to 95% RH. and dwell should be 1.0 hour.	1: No physical damage. 2: 20 m Ω maximum change from initial
Temperature life (preconditioning)	EIA-364-17, Method A. Subject mated connectors to temperature life at +90°C for 816 hours.	1: No physical damage. 2: 20 m Ω maximum change from initial
Thermal disturbance	Cycle the mated connector between 15°C \pm 3°C and 85°C \pm 3°C, as measured on the part. Ramps should be a minimum of 2°C per minute, and dwell times should insure that the contacts reach the temperature extremes (a minimum of 5 minutes). Humidity is not controlled. Perform 10 such cycles.	1: No physical damage. 2: 20 m Ω maximum change from initial

PROPRIETARY NOTICE

This product specifications, herein, are the property Of Genesis Connected Solutions and shall not be reproduced or copied or used in whole or in part as the basis for manufacture or sale of items without written permission.

Size
A

SPEC PART NUMBER:
230-10047-XX

Revision01



Page: 5 of 7

PRODUCT SPECIFICATION

Solderability	EIA 364-52 At a temperature of 245+5°C for 5+0.5 seconds. Dip tails into flux for 5 second, drain, and then dip into the solder pot and keep for 5 seconds. steam aging 8 hours and let stand for more than 30 minutes	More than 95% of the Solder-able area shall be covered with solder
Resistance to Solder reflow Heat	1). Reflow part Max 260°C ± 5°C for 10sec. 2). Pre-heat part 130~180°C,60~120 sec *The number of times through reflow oven is 2 times Per EIA-364-56	Tested housing shall show no evidence of deformation and no physical damage.
Mixed Flowing Gas	EIA-364-65 , Class IIA, 7 Days, 1) Expose 3/5 of the specimens unmated for 2/3 of the test duration; 2) mate each specimen to the same plug that it was mated to during temperature life (preconditioning); and, 3) expose for the remainder of the test duration.	1: No physical damage. 2: 20 m Ω maximum change from initial

4.0 PRODUCT QUALIFICATION AND REQUALIFICATION TEST SEQUENCE

Table 3

Test Group 	A	B	C	D	E	F	G	H	I
Test or examination 									
Sample size	5	5	5	5	5	5	5	5	1
Examination of product	1,9	1,8	1,5	1,7	1,3	1,5	1,4	1,3	1
Insulation Resistance				2,5					
Dielectric Withstanding Voltage				3,6					
Low level contact resistance	2,8	3,5,7	2,4			2,5,7,9			
SI Profile									2
Temperature Rise								2	
Mating Force	3,6								
Unmating Force	4,7								
Durability	5								
Durability (Preconditioning)		2				3			
Physical shock		6							

PROPRIETARY NOTICE This product specifications, herein, are the property Of Genesis Connected Solutions and shall not be reproduced or copied or used in whole or in part as the basis for manufacture or sale of items without written permission.	Size A	SPEC PART NUMBER: 230-10047-XX	Revision01	Page: 6 of 7

GENESIS CONNECTED SOLUTIONS**PRODUCT SPECIFICATION**

Vibration		4							
Humidity			3						
Temperature life (Preconditioning)						4			
Thermal disturbance						8			
Thermal shock				4					
Mix Flowing Gas						6			
Solderability					2				
Resistance to Solder reflow Heat							2		

NOTES:

1. Shall meet EIA 364-18 Visual Examination requirements, show no physical damage, and shall meet requirements of additional tests as specified in the test sequence.
2. Vibration test fixture is to be determined by each user with connector vendors.

PROPRIETARY NOTICE

This product specifications, herein, are the property Of Genesis Connected Solutions and shall not be reproduced or copied or used in whole or in part as the basis for manufacture or sale of items without written permission.

Size
ASPEC PART NUMER:
230-10047-XX

Revision01

Page: 7 of 7