



SPECIFICATION

宏致電子股份有限公司

桃園縣中壢市東園路13號

No.13, Dong yuan Rd., Jhongli City,

Taoyuan County 320, Taiwan (R.O.C.)

TEL: +886-3-463-2808

FAX: +886-3-463-1800

SPEC. NO.: PS-50224-XXXXX-XXX REVISION: V

PRODUCT NAME: 1.0 mm PITCH WTB WAFER CONNECTOR

PRODUCT NO: 50224,50225,20227,50233,50446, 51244,
51262,50408,50409,51305,51325,EA30E,70224 SERIES

PREPARED:	CHECKED:	APPROVED:
GAOLI	XUZHIYONG	XUZHIYONG
DATE: 2022.12.07	DATE: 2022.12.07	DATE: 2022.12.07



AcesP/N:50224,50225,20227,50233,50446,51244,51262,50409,50408,51305,51325,EA30E,70224 SERIES

TITLE: 1.0 mm PITCH WTB WAFER CONNECTOR

RELEASE DATE: 2022.12.07

REVISION:V

ECN No: ECN-010686

PAGE: 2 OF 16.

1	REVISION HISTORY	3
2	SCOPE	4
3	APPLICABLE DOCUMENTS.....	4
4	REQUIREMENTS	4
5	PERFORMANCE	5
6	INFRARED REFLOW CONDITION	8
7	PRODUCT QUALIFICATION AND TEST SEQUENCE.....	9
8	MATING / UNMATING FORCE.....	10
9	ANATOMY OF CRIMPING TERMINAL.....	11
10	APPLICABLE WIRES: UL3302 ETFE WIRE	11
11	CRIMPING CONDITION	12
12	CRIMPING HEIGHT MEASUREMENT	13
13	PULL FORCE OF CRIMPING SECTION MEASUREMENT	14
14	STANDARD INSULATION CRIMPING	14
15	CONDUCTORS CRIMPING CONDITION	15
16	CRIMPING REQUIREMENT.....	16



AcesP/N:50224,50225,20227,50233,50446,51244,51262,50409,50408,51305,51325,EA30E,70224 SERIES

TITLE: 1.0 mm PITCH WTB WAFER CONNECTOR

RELEASE DATE: 2022.12.07

REVISION:V

ECN No: ECN-010686

PAGE: 3 OF 16.

1 REVISION HISTORY

Rev.	ECN #	Revision Description	Prepared	Date
O	ECN-0812248	NEW SPEC	JASON	2008.11.22
A	ECN-0909088	FOR ADW0909020 ADD HAND SOLDERING	JASON	2009.09.11
B	ECN-1006083	MODIFY TERMINAL RETENTION FORCE	JASON	2009.09.11
C	ECN-1009004	FOR APP990202 ADD50446	YUIXIANG	2010.06.03
D	ECN-1101087	MODIFY TERMINAL RETENTION FORCE	HUANTY	2010.09.01
E	ECN-1108376	ADD CRIMPING	GAVIN	2011.08.19
F	ECN-1305409	FOR APD1020152 ADD 51244	SKQI	2013.07.11
G	ECN-1310032	MODIFY TERMINAL CURRENT VALUE	DAVID	2013.10.07
H	ECN-1501221	FOR APD1030143 ADD 51262	XIUJIN	2014.10.18
J	ECN-1504471	ADD50409;50408	XIUJIN	2015.04.25
K	ECN-1506267	MODIFY VOLTAGE AND ADD WORKING VOLTAGE	CHENYA	2015.06.13
L	ECN-1511199	ADD 51305 SERIES	CHENYA	2015.08.26
M	ECN-1601092	ADD 51325 SERIES	XIAOXIONG	2016.01.06
N	ECN-1603439	MODIFY OPERATING TEMPERATURE	CHENYA	2016.03.15
P	ECN-1604221	ADD EA30E SERIES	CHENYA	2016.04.15
Q	ECN-1608059	ADD 28PIN STANDARD	XIUJIN	2016.08.03
R	ECN-1805129	ADD 50233 SERIES	ZHANGHAO	2018.05.09
S	ECN-1809051	Update Salt Spray	SHI,YANAN	2018.08.31
T	ECN-1908220	ADD 70224 SERIES	LU,TAOTAO	2019.08.16
U	ECN-2002136	Update AWG#28 Current	SHI,YANAN	2020/02/27
U1	ECN-007974	ADD 71212 SERIES	GAOLI	2022/05/10
V	ECN-010686	Cancel 71212 SERIES	GAOLI	2022/12/07

TITLE: 1.0 mm PITCH WTB WAFER CONNECTOR

RELEASE DATE: 2022.12.07

REVISION:V

ECN No: ECN-010686

PAGE: 4 OF 16.

2 SCOPE

This specification covers performance, tests and quality requirements for 1.0 mm pitch WTB wafer SMT T/H Type. These connectors are this Product SPEC. refer to Aces's

P/N: 50224Series ; 50225Series ; 50227Series ; ;50233 Series ;50446Series;50409Series; 50408 Series;51305 Series;51325 Series;EA305 Series;70224Series

3 APPLICABLE DOCUMENTSS

EIA-364: ELECTRONICS INDUSTRIES ASSOCIATION

4 REQUIREMENTS

4.1 Design and Construction

4.1.1 Product shall be of design, construction and physical dimensions specified on applicable product drawing.

4.1.2 All materials conform to R.o.H.S. and the standard depends on TQ-WI-140101.

4.2 Materials and Finish

4.2.1 Contact: High performance copper alloy.

Finish: (a) Contact Area: Refer to the drawing.

(b) Under plate: Refer to the drawing.

(c) Solder area: Refer to the drawing.

4.2.2 Housing: Thermoplastic or Thermoplastic High Temp., UL94V-0

4.2.3 Fitting Nail: Copper Alloy,

Finish: Refer to the drawing.

4.3 Ratings

4.3.1 Working voltage less than 36 volts (per pin)

4.3.2 Voltage: 50 Volts AC (per pin)

4.3.3 Current: AWG#28: 2.5 Amperes (per pin)

AWG#30: 1 Amperes (per pin)

AWG#32: 1 Amperes (per pin)

AWG#34: 0.8 Amperes (per pin)

4.3.4 Operating Temperature : -40°C to +85°C

TITLE: 1.0 mm PITCH WTB WAFER CONNECTOR

RELEASE DATE: 2022.12.07

REVISION:V

ECN No: ECN-010686

PAGE: 5 OF 16.

5 Performance

5.1. Test Requirements and Procedures Summary

Item	Requirement	Standard
Examination of Product	Product shall meet requirements of applicable product drawing and specification.	Visual, dimensional and functional per applicable quality inspection plan.
ELECTRICAL		
Item	Requirement	Standard
Low Level Contact Resistance	10 m Ω Max.(initial)per contact ΔR 10 m Ω Max.	Mate connectors, measure by dry circuit, 20mV Max., 10mA Max. (EIA-364-23)
Insulation Resistance	100 M Ω Min.	Unmated connectors, apply 500 V DC between adjacent terminals. (EIA-364-21)
Dielectric Withstanding Voltage	No discharge, flashover or breakdown. Current leakage: 1 mA max.	250V AC Min. at sea level for 1 minute. Test between adjacent contacts of unmated connectors. (EIA-364-20)
Temperature Rise	30°C Max. Change allowed	Mate connector: measure the temperature rise at rated current until temperature stable. The ambient condition is still air at 25°C (EIA-364-70,METHOD1,CONDITION1)
MECHANICAL		
Item	Requirement	Standard
Durability	30 cycles.	The sample should be mounted in the tester and fully mated and unmated the number of cycles specified at the rate of 25.4 ± 3mm/min.
Mating / Unmating Forces	Please see Item 8	Operation Speed: 25.4 ± 3 mm/minute.. Measure the force required to mate/unmate connector. (EIA-364-13)
Contact Retention Force (Board Side)	0.40 Kgf Min.	Operation Speed: 25.4 ± 3 mm/minute. Measure the contact retention force with tester.
Crimping Terminal / Housing Retention Force (Cable Side)	0.7 Kgf MIN.	Apply axial pull out force at the speed rate of 25.4 ± 3 mm/minute. On the terminal assembled in the housing.



AcesP/N:50224,50225,20227,50233,50446,51244,51262,50409,50408,51305,51325,EA30E,70224 SERIES

TITLE: 1.0 mm PITCH WTB WAFER CONNECTOR

RELEASE DATE: 2022.12.07

REVISION:V

ECN No: ECN-010686

PAGE: 6 OF 16.

Crimping Pull Out Force	AWG# 28: 1.0Kgf Min. AWG# 30: 0.5Kgf Min. AWG# 32: 0.3Kgf Min.	Operation Speed: 25.4 ± 3 mm/minute. Fix the crimped terminal, apply axial pull out force on the wire.
Vibration	1 µs Max.	The electrical load condition shall be 100 mA maximum for all contacts. Subject to a simple harmonic motion having amplitude of 0.76mm (1.52mm maximum total excursion) in frequency between the limits of 10 and 55 Hz. The entire frequency range, from 10 to 55 Hz and return to 10 Hz, shall be traversed in approximately 1 minute. This motion shall be applied for 2 hours in each of three mutually perpendicular directions. (EIA-364-28 Condition I)
Shock (Mechanical)	1 µs Max.	Subject mated connectors to 50 G's (peak value) half-sine shock pulses of 11 milliseconds duration. Three shocks in each direction shall be applied along the three mutually perpendicular axes of the test specimen (18 shocks). The electrical load condition shall be 100mA maximum for all contacts. (EIA-364-27, test condition A)

ENVIRONMENTAL

Item	Requirement	Standard
Resistance to Wave Soldering Heat (Board Side)	See Product Qualification and Test Sequence Group 10 (Lead Free)	Solder Temp.: 265±5°C, 10±0.5sec.
Resistance to Reflow Soldering Heat (Board Side)	See Product Qualification and Test Sequence Group 10 (Lead Free)	Pre Heat: 150°C~180°C, 60~120sec. Heat: 230°C Min., 40sec Min. Peak Temp.: 260°C Max, 10sec Max.
Thermal Shock	See Product Qualification and Test Sequence Group 4	Mate module and subject to follow condition for 5 cycles. 1 cycles: -55 +0/-3 °C, 30 minutes +85 +3/-0 °C, 30 minutes (EIA-364-32, test condition I)
Humidity	See Product Qualification and Test Sequence Group 4	Mated Connector 40°C, 90~95% RH, 96 hours.



AcesP/N:50224,50225,20227,50233,50446,51244,51262,50409,50408,51305,51325,EA30E,70224 SERIES

TITLE: 1.0 mm PITCH WTB WAFER CONNECTOR

RELEASE DATE: 2022.12.07

REVISION:V

ECN No: ECN-010686

PAGE: 7 OF 16.

		(EIA-364-31, Condition A, Method II)
Temperature Life	See Product Qualification and Test Sequence Group 5	Subject mated connectors to temperature life at 85°C for 96 hours. (EIA-364-17, Test condition A)
Salt Spray (Only For Gold Plating)	See Product Qualification and Test Sequence Group 6	Subject mated/unmated connectors to 5% salt-solution concentration, 35°C (I) Gold flash for 8 hours (II) Gold plating 3 u" for 48 hours. (II) Gold plating 5 u"(Min) for 96 hours. (EIA-364-26)
Solder ability (Board Side)	Tin plating: Solder able area shall have minimum of 95% solder coverage. Gold plating: Solder able area shall have minimum of 75% solder coverage	And then into solder bath, Temperature at 245 ±5°C, for 4-5 sec. (EIA-364-52)
Hand Soldering Temperature Resistance (Board Side)	Appearance: No damage	T ≥ 350°C, 3sec at least.

Note. Flowing Mixed Gas shall be conducted by customer request.

\

TITLE: 1.0 mm PITCH WTB WAFER CONNECTOR

RELEASE DATE: 2022.12.07

REVISION:V

ECN No: ECN-010686

PAGE: 8 OF 16.

6 INFRARED REFLOW CONDITION

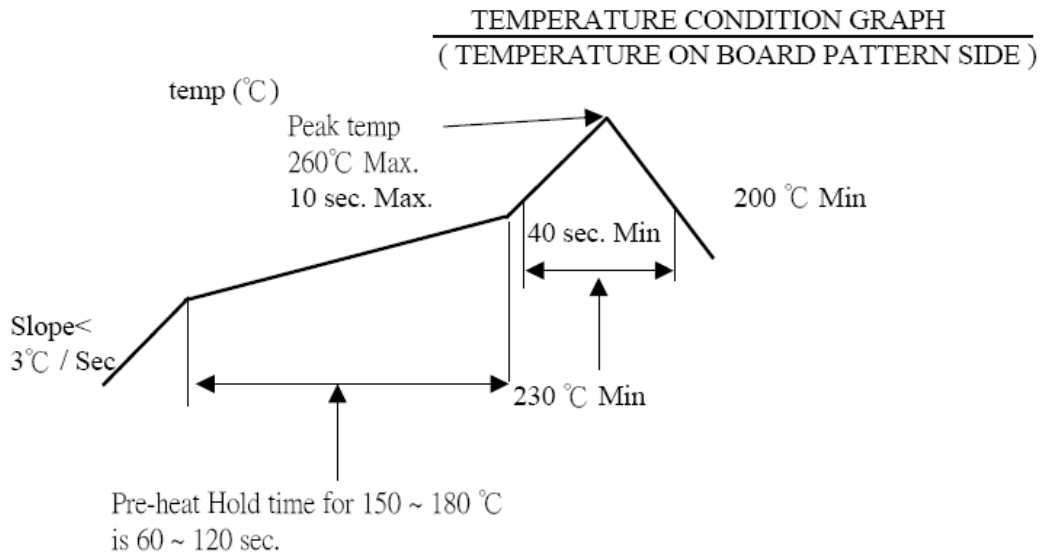



TITLE: 1.0 mm PITCH WTB WAFER CONNECTOR

RELEASE DATE: 2022.12.07

REVISION:V

ECN No: ECN-010686

PAGE: 9 OF 16.

7 PRODUCT QUALIFICATION AND TEST SEQUENCE

Test or Examination	Test Group										
	1	2	3	4	5	6	7	8	9	10	11
	Test Sequence										
Examination of Product				1、7	1、6	1、4				1	1
Low Level Contact Resistance		1、5	1、4	2、10	2、9	2、5				3	
Insulation Resistance				3、9	3、8						
Dielectric Withstanding Voltage				4、8	4、7						
Temperature Rise	1										
Mating / Unmating Force		2、4									
Durability		3									
Contact Retention Force (Board Side)									2		
Vibration			2								
Shock (Mechanical)			3								
Thermal Shock				5							
Humidity				6							
Temperature Life					5						
Salt Spray (Only For Gold Plating)						3					
Solder ability (Board Side)							1				
Crimping Pull Out Force								1			
Crimping Terminal / Housing Retention Force (Cable Side)									1		
Resistance to Soldering Heat (Board Side)										2	
Hand Soldering Temperature Resistance (Board Side)											2
Sample Size	2	4	4	4	4	4	2	4	4	4	4



TITLE: 1.0 mm PITCH WTB WAFER CONNECTOR

RELEASE DATE: 2022.12.07

REVISION:V

ECN No: ECN-010686

PAGE: 10 OF 16.

8 MATING / UNMATING FORCE

Unit: N

Number of circuits	At initial		At 30th
	I.F.(MAX.)	W.F.(MIN.)	W.F.(MIN.)
2	25	2	2
3	25	2	2
4	30	2	2
5	30	3	3
6	35	3	3
7	35	3	3
8	40	4	4
9	40	4	4
10	45	4	4
11	50	5	5
12	50	5	5
13	55	5	5
14	60	6	6
15	60	6	6
16	65	6	6
18	70	7	7
20	75	7	7
22	80	7	7
24	85	8	8
26	95	8	8
28	95	8	8

TITLE: 1.0 mm PITCH WTB WAFER CONNECTOR

RELEASE DATE: 2022.12.07

REVISION:V

ECN No: ECN-010686

PAGE: 11 OF 16.

9 ANATOMY OF CRIMPING TERMINAL

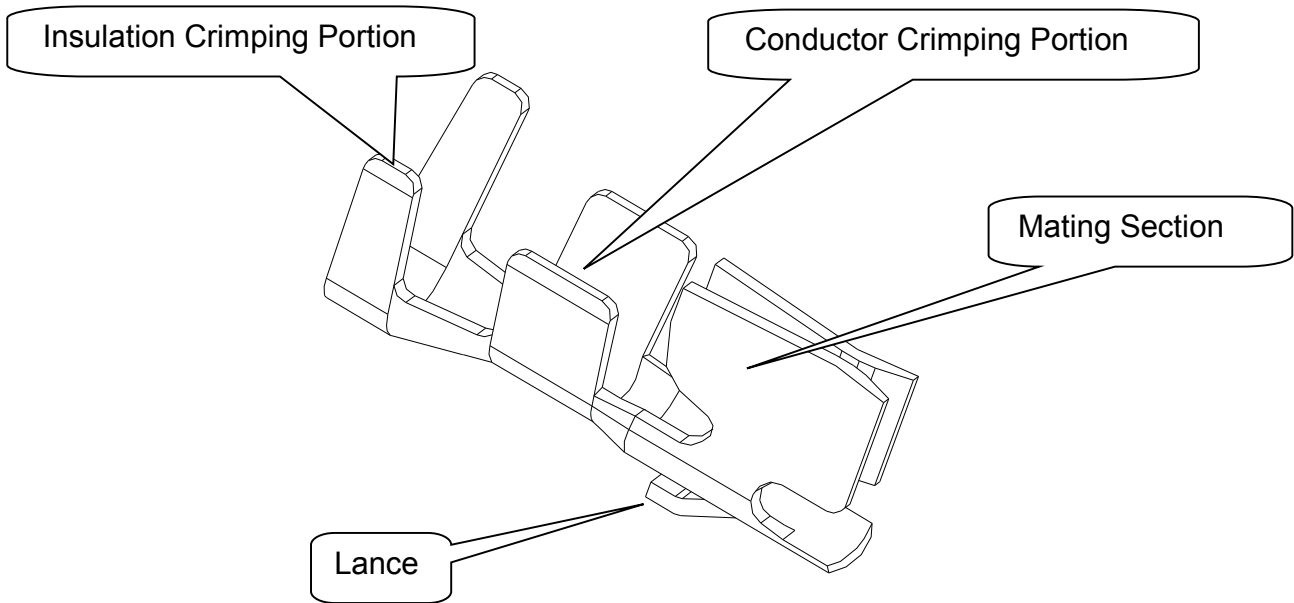

The crimping contact drawing is for reference only. May Not be the same with this P/N

10 APPLICABLE WIRES: UL3302 AND UL1571(AWG#34) ETFE WIRE

- AWG Size:AWG#28 Insulation OD: Φ 0.65mm
- AWG Size:AWG#30 Insulation OD: Φ 0.70mm
- AWG Size:AWG#32 Insulation OD: Φ 0.60mm
- AWG Size:AWG#34 Insulation OD: Φ 0.31~0.33mm

TITLE: 1.0 mm PITCH WTB WAFER CONNECTOR

RELEASE DATE: 2022.12.07

REVISION:V

ECN No: ECN-010686

PAGE: 12 OF 16.

11 CRIMPING CONDITION

鉚線條件表 CRIMPING CONDITION

Part Number	Wire Specification			Crimp Height (mm)		Crimp Width (mm)	
	UL Style (REF.)	AWG Size	Insulation OD(mm)	Conductor A	Insulation B	Conductor W1	Insulation W2
87214-W	UL3302	28	0.65	0.80Max	1.05~1.15	0.55~0.65	0.80Max
87214-W	UL3302	30	0.70	0.75Max	1.10~1.20	0.50~0.60	0.80Max
87214-W	UL3302	32	0.60	0.60Max	1.00~1.10	0.50~0.60	0.80Max
50211-T	UL1571	34	0.31~0.33	0.35~0.42	0.74~0.76	0.70(參考值)	0.70~0.75

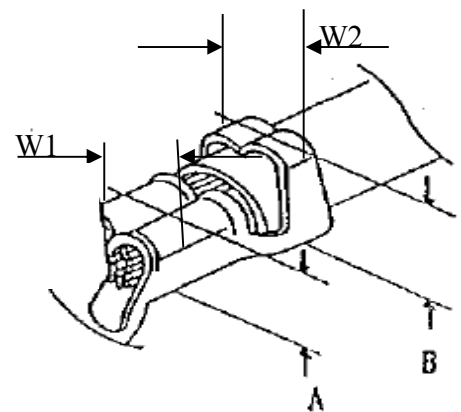
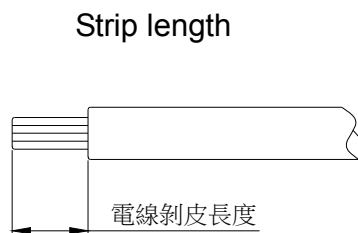

Note:

- 1、W1為芯線導體鉚壓後之寬度(Conductor Crimping Width): W1值如上表
- 2、W2為電線外被部分鉚壓後之寬度(Insulation Crimping Width): W2值如上表
- 3、A為芯線導體鉚壓後之高度(Conductor Crimping height): A值如上表(參考值)
- 4、B為電線外被鉚壓後之高度(Insulation Crimping height): B值如上表(參考值)
- 5、電線剝皮長度(Strip length): 1.3~1.6mm (參考值)

TITLE: 1.0 mm PITCH WTB WAFER CONNECTOR

RELEASE DATE: 2022.12.07

REVISION: V

ECN No: ECN-010686

PAGE: 13 OF 16.

12 CRIMPING HEIGHT MEASUREMENT

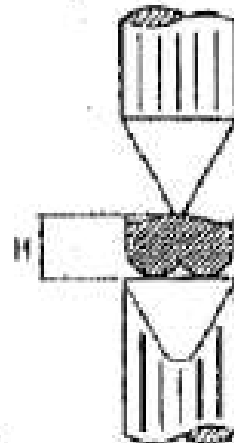
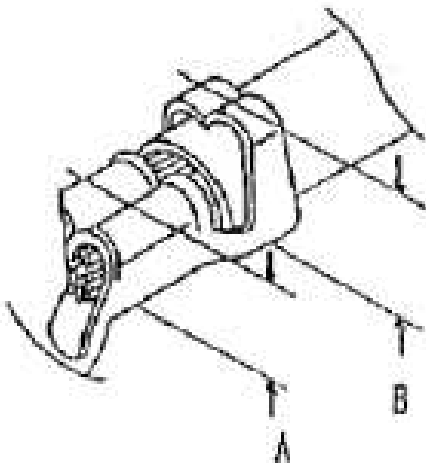
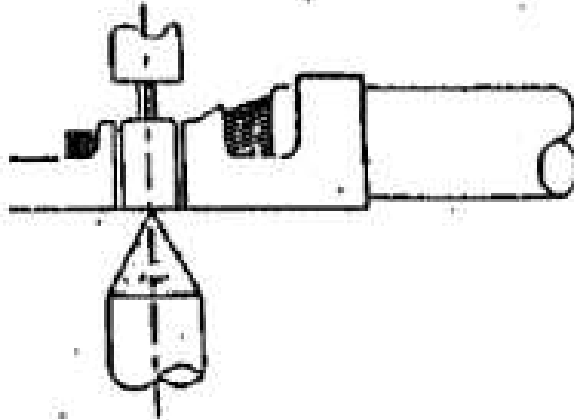
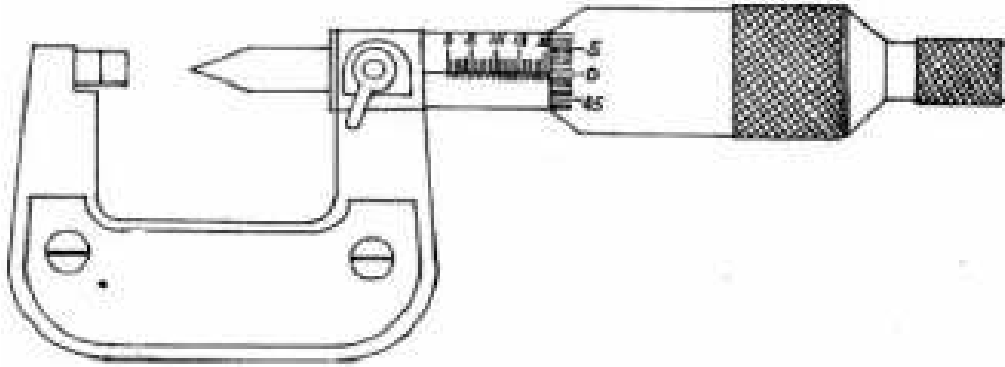

TITLE: 1.0 mm PITCH WTB WAFER CONNECTOR

RELEASE DATE: 2022.12.07

REVISION:V

ECN No: ECN-010686

PAGE: 14 OF 16.

13 PULL FORCE OF CRIMPING SECTION MEASUREMENT



Before test samples, please measure crimp height and do not crimp insulation.

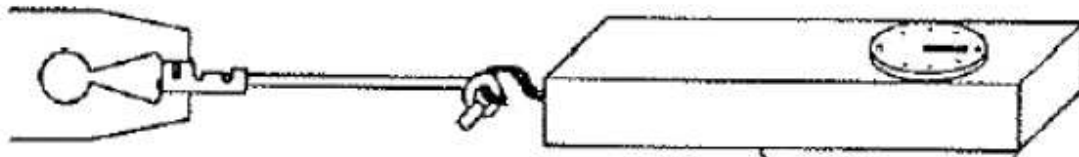

Pull Force of Crimp Section Measurement

14 STANDARD INSULATION CRIMPING

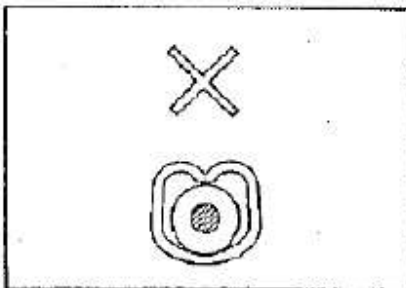

Not enough crimp

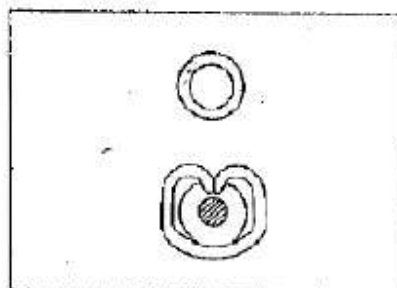

Good

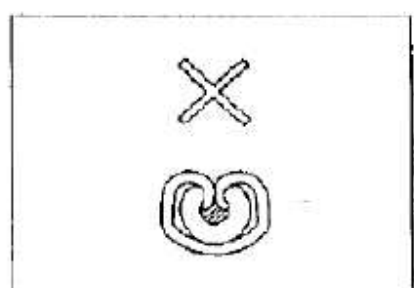

Crimp too much

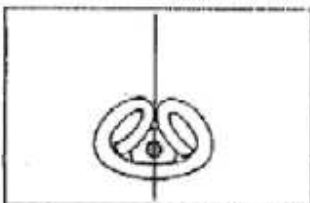

Good

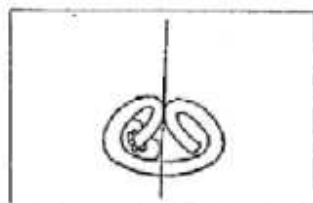

NG

Insulation Crimp Condition

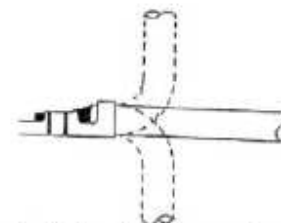

As following figure shown. It is no problem if wire bent up down 90 degrees 1 cycle and insulation position still in ideal position.

TITLE: 1.0 mm PITCH WTB WAFER CONNECTOR

RELEASE DATE: 2022.12.07

REVISION:V

ECN No: ECN-010686

PAGE: 15 OF 16.

15 CONDUCTORS CRIMPING CONDITION

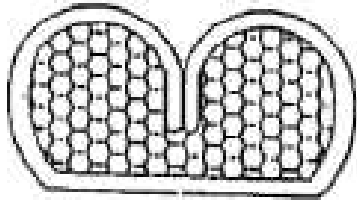

○ Good

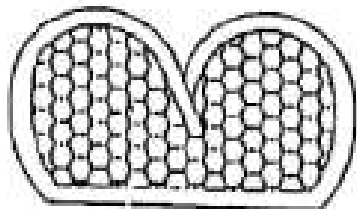

✗ NG

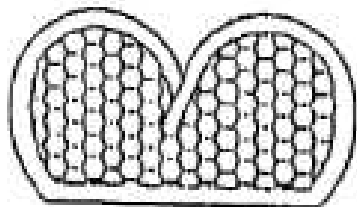

✗ NG

Lower conduct retention force

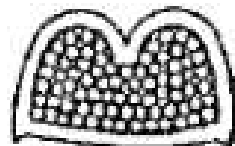

Good

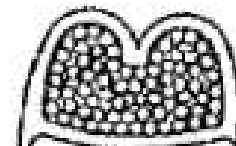

NG

Large burr

TITLE: 1.0 mm PITCH WTB WAFER CONNECTOR

RELEASE DATE: 2022.12.07

REVISION:V

ECN No: ECN-010686

PAGE: 16 OF 16.

16 CRIMPING REQUIREMENT

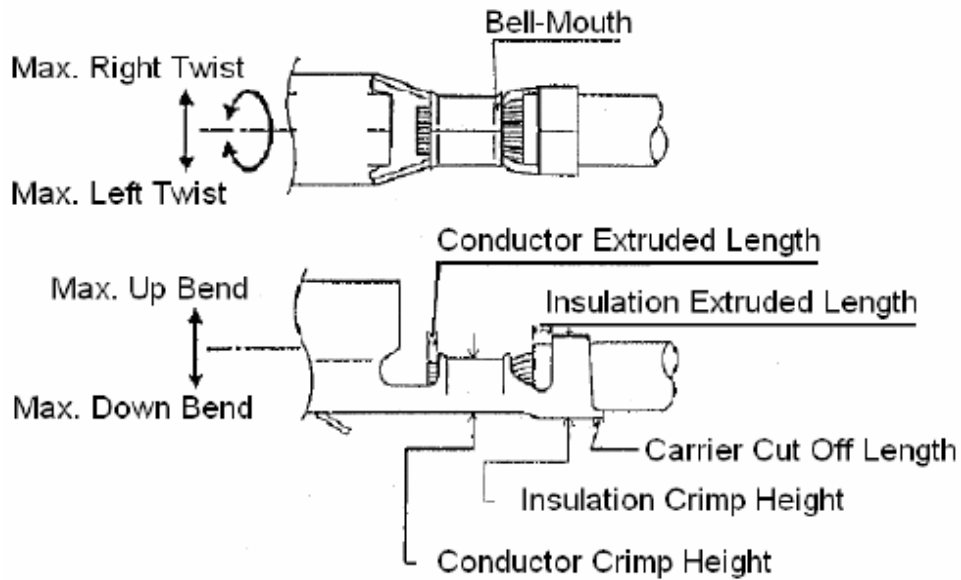

Item	Range(Ref.)
Max. Up Bend	6°
Max. Down Bend	6°
Max. Left Twist	5°
Max. Right Twist	5°
Bell-Mouth Length	0.1~0.3mm
Carrier Cut Off Length	0~0.2mm
Conductor Extruded Length	0.05~0.2mm