

RECOMMENDED PCB LAYOUT (TOP VIEW)
(TOLERANCE=±0.05mm ; THICKNESS=1.0t)

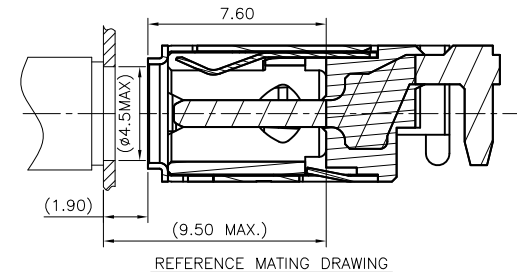
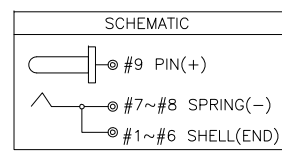
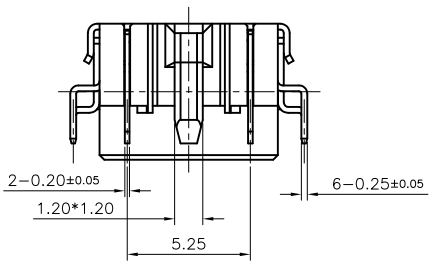
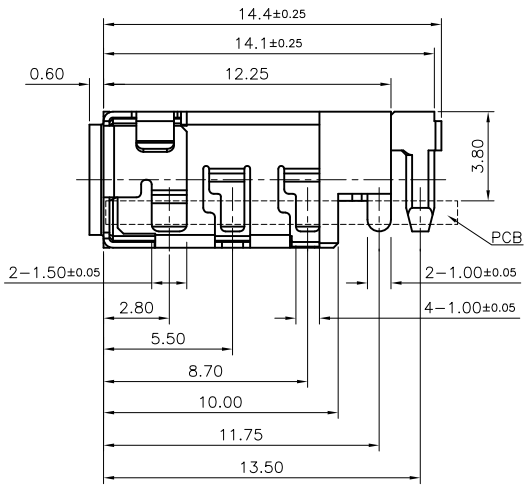
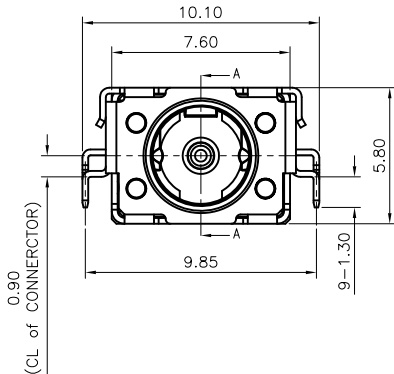

- NOTES:
- MATERIAL: SEE TABLE
PLATING: TERMINAL: GOLD PLATED ON CONTACT AREA, AND MATTE-TIN 60~150u" ON SOLDER AREA
SHELL: NICKEL PLATED 60u"MIN.
 - THE CAVITY, LOGO MAX HEIGHT 0.10mm ABOVE SURFACE. THE TEXT HEIGHT IS ABOUT 1mm.
 - IF ANY DIMENSIONS OR DRAFT ANGLES WEREN'T MARKED, PLS. REFER TO 3D DRAWING
 - ELECTRICAL CHARACTERISTICS:
 - RATING: 20V 5A
 - CONTACT RESISTANCE: INITIAL 10mΩ MAX; AFTER 15mΩ MAX
 - DIELECTRIC WITHSTANDING VOLTAGE: 500V AC FOR ONE MINUTE
 - INSULATION RESISTANCE: 100MΩ MIN. MEASURED BY 500 VDC
 - MECHANICAL CHARACTERISTICS:
 - INSERTION FORCE: 0.8~2.0kg. (INITIAL & AFTER LIFE TEST)
 - WITHDRAWAL FORCE: 0.8~2.0kg. (INITIAL & AFTER LIFE TEST)
 - LIFE TEST: 8,000 CYCLES MIN
 - SPEC. PLS. REFER TO SPEC-58901-XXXX-XXX
 - PACKAGE PLS. REFER TO 58913-002XX-XXX-PCK
 - PART NUMBER 58913-002 X X -XXX

REV.	ECN NO OR DESCRIPTION	REVISED	DATE
0	PDR NO: APD1040145	MARK-C	2015.07.14
A	MODIFY SPEC P/N	MARK-C	2016.01.25
B	MODIFY MATING DRAWING	MARK-C	2016.12.21

CKT: 001: NONE
PLATING: 2: GOLD FLASH
PACKING: 0: TAPE & REEL

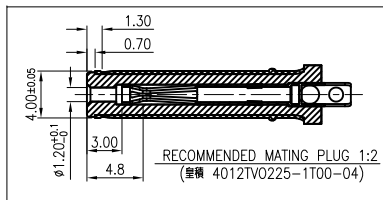
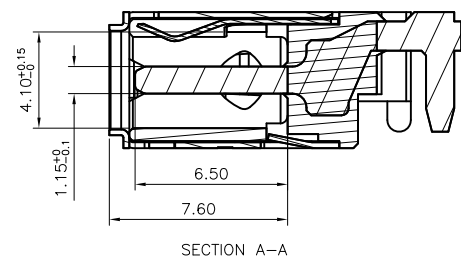
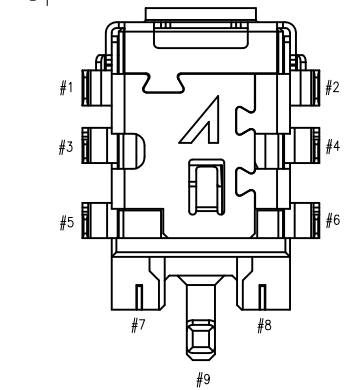

NO	DESCRIPTION	Q'TY	MATERIAL	PLATING & COLOR
C	SHELL	1	SUS304-1/2H, 0.25T	NICKEL PLATED
B	SIGNAL	1	C5210-EH, 0.2T	TIN PLATED
A	INSERT MOLDING	1	PIN:C2680-H, 1.2T	GOLD FLASH
		1	BODY:PA4T+30%GF UL94V-0	BLACK

宏致電子股份有限公司
Aces Electronics Co., Ltd.

品名 (TITLE): 4φ DC POWER JACK (CH:0.9)
製圖 (DR): '16/12/21 MARK-C
審核 (CHKD): BRUCE
圖號 (DWG NO.): 58913-00202-001
核准 (APPD): JACK

表面處理 (FINISH):
比例 (SCALE): 3.2:1
單位 (UNITS): mm
張數 (SHEET): 1 OF 2
SIZE: A4
REV: B



MATING DRAWING

1. 負極接觸狀態

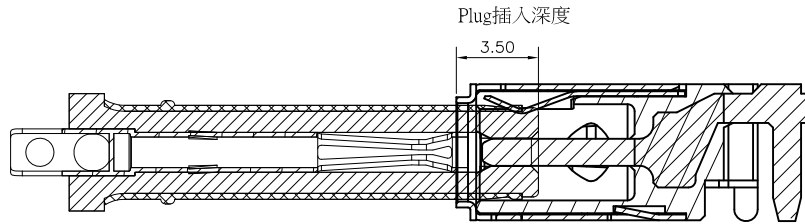

3. Lock狀態

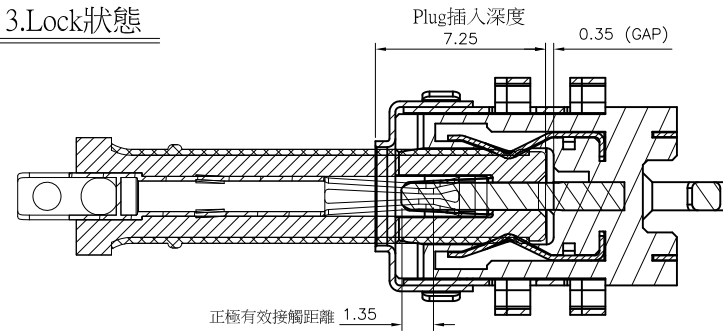

2. 正極接觸狀態

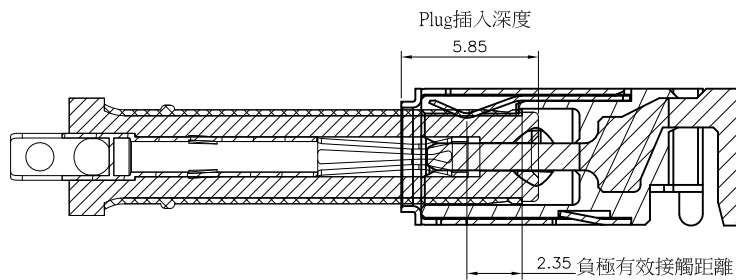

4. Plug插到底狀態

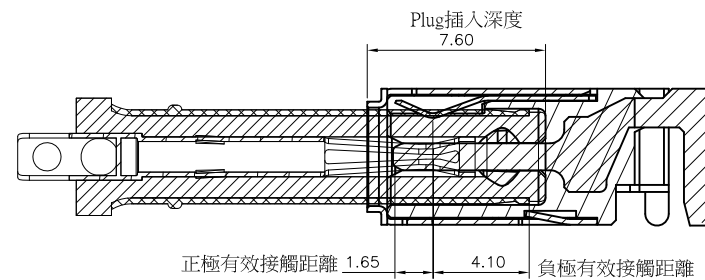

一般公差 TOLERANCES X ±0.5 XX ±0.15 X ±0.25 .XXX ±0.1 ANGLES ±2°		宏致電子股份有限公司 Aces Electronics Co.,Ltd.	
檢驗尺寸標示 SYMBOLS INDICATE CLASSIFICATION DIMENSION MARK IS CRITICAL DIM. MARK IS MAJOR DIM.		品名 (TITLE) 4φ DC POWER JACK (CH:0.9)	製圖 (DR) '16/12/21 MARK-C 審核 (CHKD) BRUCE
		圖號 (DWG NO.) 58913-00202-001	核准 (APPD) JACK
表面處理 (FINISH)	比例 (SCALE) 3.2:1	單位 (UNITS) mm	張數 (SHEET) 2 OF 2
			SIZE A4
			REV B