

RECOMMENDED PCB LAYOUT
GENERAL TOLERANCE ± 0.05

NOTES:

1. MATERIAL:

- 1.1 HOUSING: THERMOPLASTIC, HIGH TEMP., UL94V-0; COLOR:BLACK.
- 1.2 CONTACT: COPPER ALLOY
- 1.3 SCREW: COPPER ALLOY

2. FINISH:

- 2.1 CONTACT:
50~100u" NICKEL UNDERPLATING OVERALL
2: GOLD FLASH PLATED ON CONTACT
- 2.2 SOLDER:
50~100u" NICKEL UNDERPLATING OVERALL
2: 100~150u" MATT TIN ON SOLDER TAIL

3. REFLOW SOLDER CAPABLE TO 260°C
PER ACES SPEC.

4. WAVE SOLDER CAPABLE TO 260°C
PER ACES SPEC.

5. SPEC. PLS. REFER TO PS-50975-xxxx-xxx

6. PACKAGE PLS. REFER TO 53047-xxxx-TRP

7. PART NUMBER

P/N LEGEND

53047-XXX X X -XXX

NO OF CKT	XXX	Color
007: 7PIN	001	Black

PACKING _____ PLATING _____

- 7:TAPE & REEL WITH COVER
- 8:TUBE WITH COVER
- 2: GOLD FLASH ON CONTACT AND 100~150u" MATT TIN ON SOLDER AREA

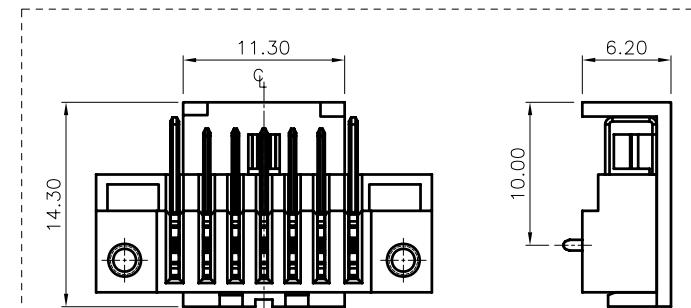

WITH COVER DRAWING

一般公差 TOLERANCES X. ± 0.5 XX ± 0.15 X ± 0.25 XXX ± 0.1 ANGLES $\pm 2^\circ$		宏致電子股份有限公司 Aces Electronics Co.,Ltd.	
檢驗尺寸標示 SYMBOLS \odot \ominus INDICATE CLASSIFICATION DIMENSION	品名 (TITLE) 2.0 mm BATTERY MALE T/H R/A S/R TYPE H=5.2mm	製圖 (DR) 13/05/02 FENGXIAO	審核 (CHKD) CARL
\odot MARK IS CRITICAL DIM. \ominus MARK IS MAJOR DIM.	圖號 (DWG NO.) 53047-XXXXX-XXX	核准 (APPD) Jason	
表面處理 (FINISH)	比例 (SCALE) 1:1	單位 (UNITS) mm	張數 (SHEET) 1 OF 1
			SIZE A4
			REV 0