

(COMPONENT SIDE)
RECOMMEND PCB LAYOUT

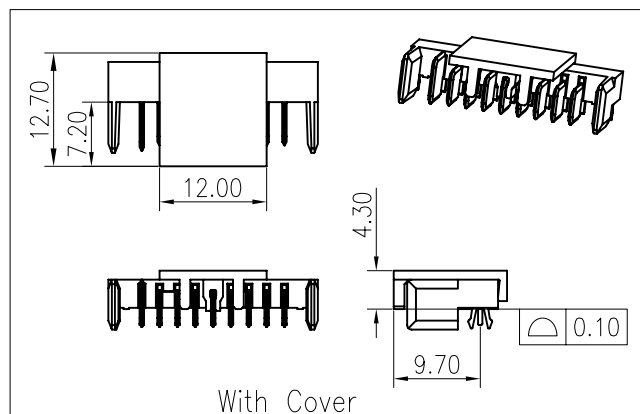
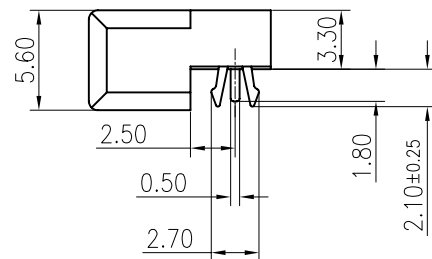

With Cover

- NOTES:
- MATERIAL:
 - HOUSING: THERMOPLASTIC, HIGH TEMP.,UL94V-0.
 - CONTACT: COPPER ALLOY.
 - HOOK: COPPER ALLOY.
 - FINISH:
 - CONTACT:
 - GOLD FLASH PLATED ON CONTACT AND SOLDER TAIL AREA. 50u" MIN. NICKEL UNDERPLATING OVERALL.
 - HOOK:
 - 50u" MIN. NICKEL UNDER PLATING OVER ALL
 - 120u" MIN. PURE TIN PLATING OVER ALL
 - REFLOW SOLDER CAPABLE TO 260°C PER ACES SPEC.
 - SPEC.PLS REFER TO PS-50975-XXXX-XXX
 - PACKAGE PLS REFER TO 53042-XXXX-03-TRP
 - PART NUMBER

53042-XXX X X-XXX					
CKTS	<table border="1"> <tr> <td>XXX</td> <td>Material&Color</td> </tr> <tr> <td>003</td> <td>LCP&Black</td> </tr> </table>	XXX	Material&Color	003	LCP&Black
XXX	Material&Color				
003	LCP&Black				
PACKING	PLATING				
0:TAPE & REEL	1: GOLD FLASH PLATED ON CONTACT AND SOLDER TAIL AREA				
1:TUBE					
7:TAPE & REEL WITH COVER					
8:TUBE WITH COVER					

一般公差 TOLERANCES X ±0.5 .XX ±0.15 X ±0.25 .XXX ±0.1 ANGLES ±2°		宏致電子股份有限公司 Aces Electronics Co.,Ltd.	
檢驗尺寸標示 SYMBOLS INDICATE CLASSIFICATION DIMENSION MARK IS CRITICAL DIM. MARK IS MAJOR DIM.		品名 (TITLE) 2.00mm Battery Conn. Male DIP R/A Type H=3.30	製圖 (DR) TANGENHUI 2013/03/08 審核 (CHKD) CARL
		圖號 (DWG NO.) 53042-XXXX-XXX	核准 (APPD) Jason
表面處理 (FINISH)	比例 (SCALE) 4:1	單位 (UNITS) mm	張數 (SHEET) 1 OF 1 尺寸 (SIZE) A4 版次 (REV) 0