

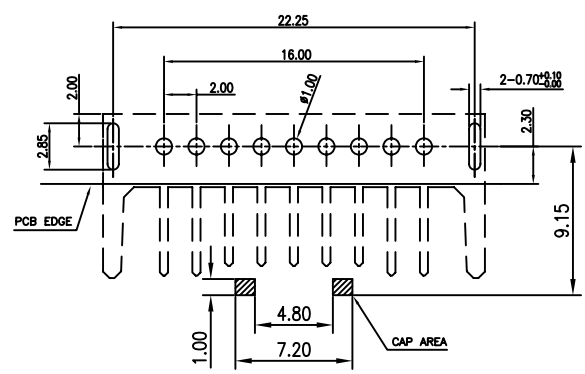

A | B | C | D | E | F

1

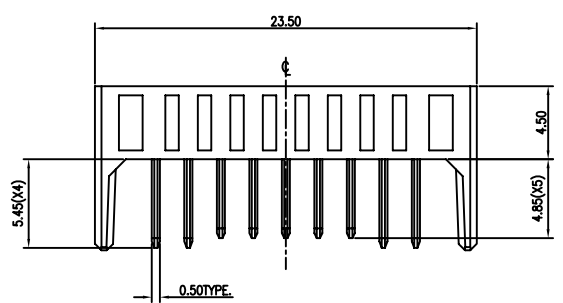

RECOMMENDED P.C.B. LAYOUT
TOLERANCE ±0.05 mm

- NOTES:
- MATERIAL:
 - HOUSING: THERMOPLASTIC, HIGH TEMP.,UL94V-0.
 - CONTACT: COPPER ALLOY.
 - HOOK: COPPER ALLOY.
 - SCREW: COPPER ALLOY.
 - FINISH:
 - CONTACT:
 - 50~100u" MIN. NICKEL UNDERPLATING OVERALL. GOLD PLATED ON CONTACT PLATING
 - SOLDER:
 - 50~100u" MIN. NICKEL UNDERPLATING OVERALL. 100~200u" MATT TIN ON SOLDER PLATING
 - HOOK:
 - 50~100u" MIN. NICKEL UNDER PLATING OVER ALL 100u" MIN. MATT TIN PLATING OVER ALL
 - REFLOW SOLDER CAPABLE TO 260°C PER ACES SPEC.
 - SPEC.PLS REFER TO PS-50975-XXXX-XXX
 - PACKAGE PLS REFER TO 53009-XXXX-XX-TRP
 - PART NUMBER

2

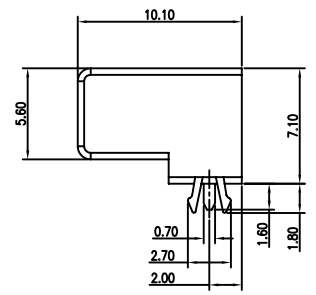
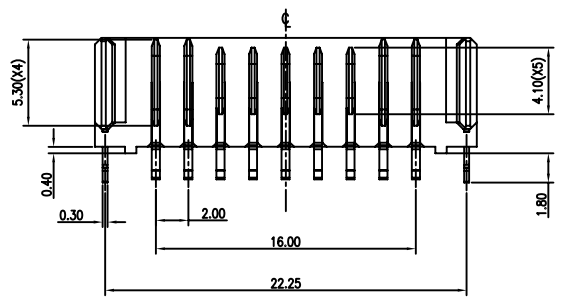

53009-XXX X X-XXX

CKTS	XXX	Housing Color
	001	Black

PACKING PLATING

0:TAPE & REEL
7:TAPE & REEL WITH COVER
8:TBUE WITH COVER

1: GOLD PLATED ON CONTACT(LEAD FREE)

3

4

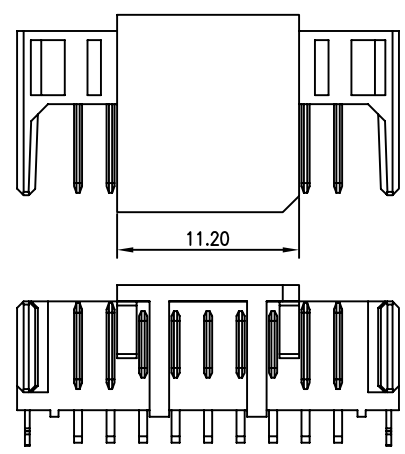

WITH COVER

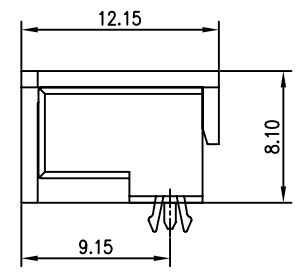

5

A | B | C | D | E | F

一般公差 TOLERANCES X ±0.5 XX ±0.15 X ±0.25 XXX ±0.1 ANGLES ±2°		宏致電子股份有限公司 Aces Electronic Co.,Ltd.	
檢驗尺寸標示 SYMBOLS (M) (L) INDICATE CLASSIFICATION DIMENSION (M) MARK IS CRITICAL DIM. (L) MARK IS MAJOR DIM.	品名 (TITLE) 2.00mm Battery Conn. Male DIP R/A Type H=7.1 圖號 (DWG.NO) 53009-XXXXX-XXX	製圖 (DR) 12/5/23 審核 (CHKD) TONY 核准 (APPD) JASON	Chenbo TONY JASON
表面處理 (FINISH)	比例 (SCALE) 1:1	單位 (UNITS) mm	張數 (SHEET) 1 OF 1 尺寸 (SIZE) A4 版次 (REV) 0

1

2

3

4

5