

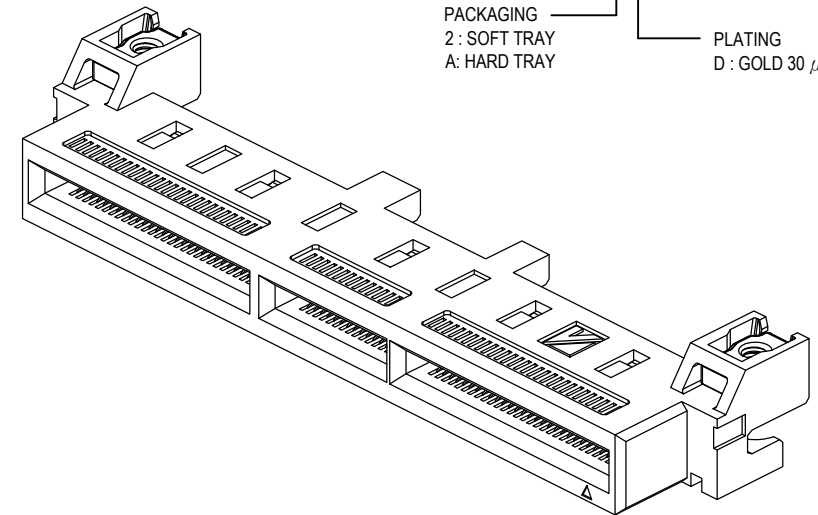

NOTES :

1. MATERIAL :
 - 1.1 HOUSING : THERMOPLASTIC, HIGH TEMP., UL94V-0; COLOR : BLACK.
 - 1.2 CONTACT : COPPER ALLOY
 - 1.3 NUT PLATE : STEEL
2. FINISH :
 - CONTACT : SEE ORDER INFORMATION.
 - SOLDER : GOLD FLASH PLATING.
 - 50-100u" NICKEL UNDERPLATED OVERALL.
3. REFLOW SOLDER CAPABLE TO 260°C PER ACES SPEC.
4. SPEC. PLS. REFER TO PS-52725-XXXXX-XXX
5. PACKAGE PLS. REFER TO 52725-140XX-XX-TRAY
6. RECOMMENDED SCREW SPEC.
 - SCREW SIZE: M2
 - SCREW LENGTH: 6mm(REF.)
 - HEAD SIZE: ϕ 3.8mm(MAX.), HEIGHT=1.6mm(MAX.)
7. PART NUMBER :

52725 - 140		X	X	- 001
NO OF CKT	140	140 CKT (4C)		
PACKAGING	2	SOFT TRAY		
A: HARD TRAY			PLATING	D : GOLD 30 μ "

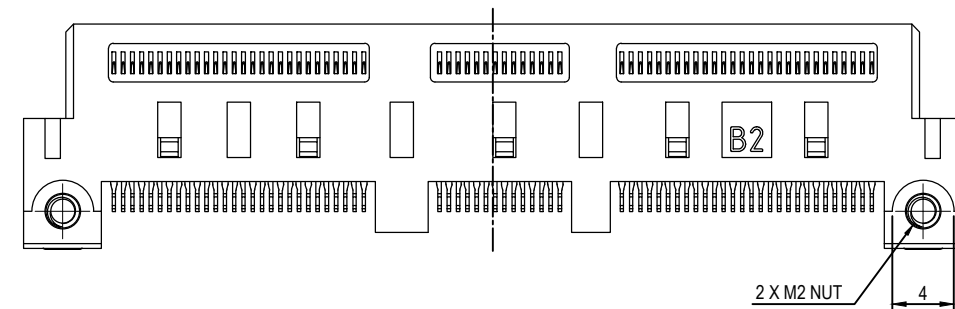
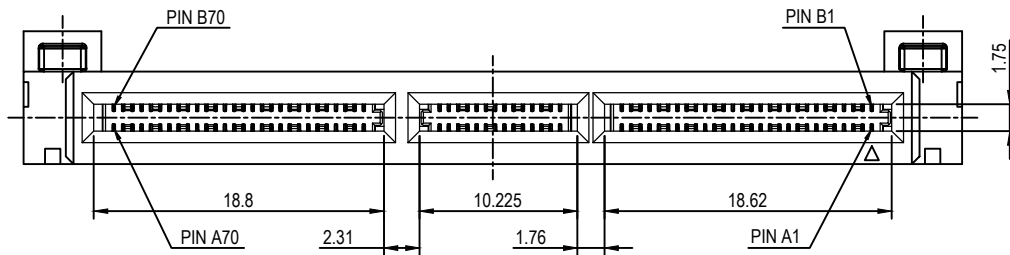
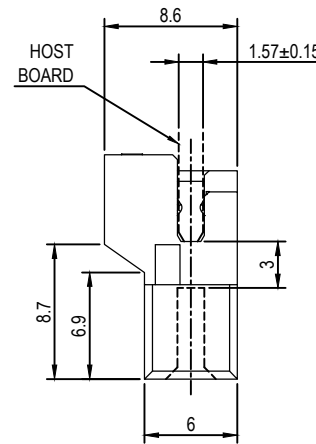
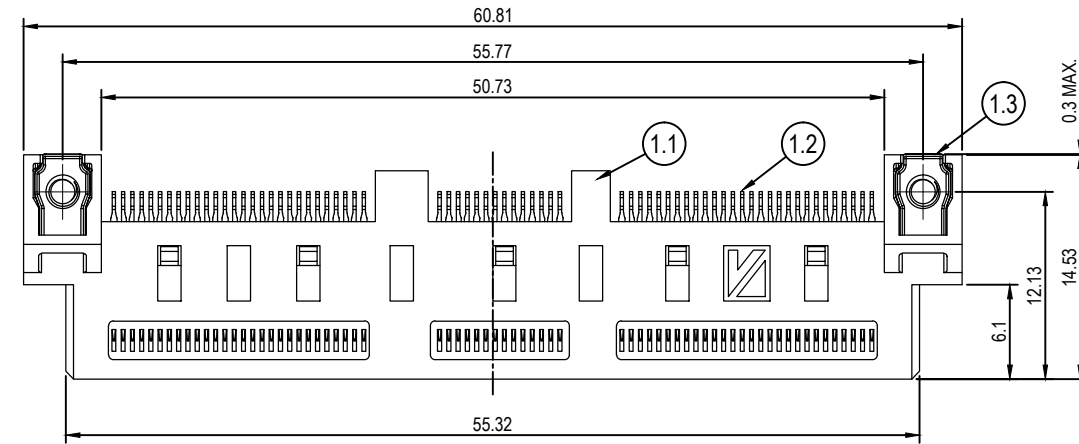

QUALITY SYMBOLS MAJOR CRITICAL GENERAL TOLERANCES (UNLESS SPECIFIED) X. ±0.5 .X ±0.25 .XX ±0.15 .XXX ±0.1 ANGLES ±2°	DRAWN BY Tseng, Chia Hsien	DATE 18/12/05	
	CHECKED BY Lin, Li Shan	DATE 18/12/05	
	APPROVED BY Chen, Po Tsang	DATE 18/12/05	RFO NO. N/A
UNITS mm		SIZE A4	DWG NO. 52725-140XX-001
SCALE 2 : 1	SHEET NO. 1 OF 3	REV	

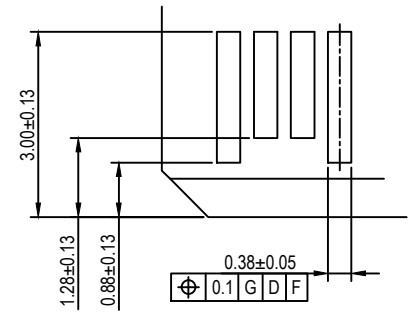
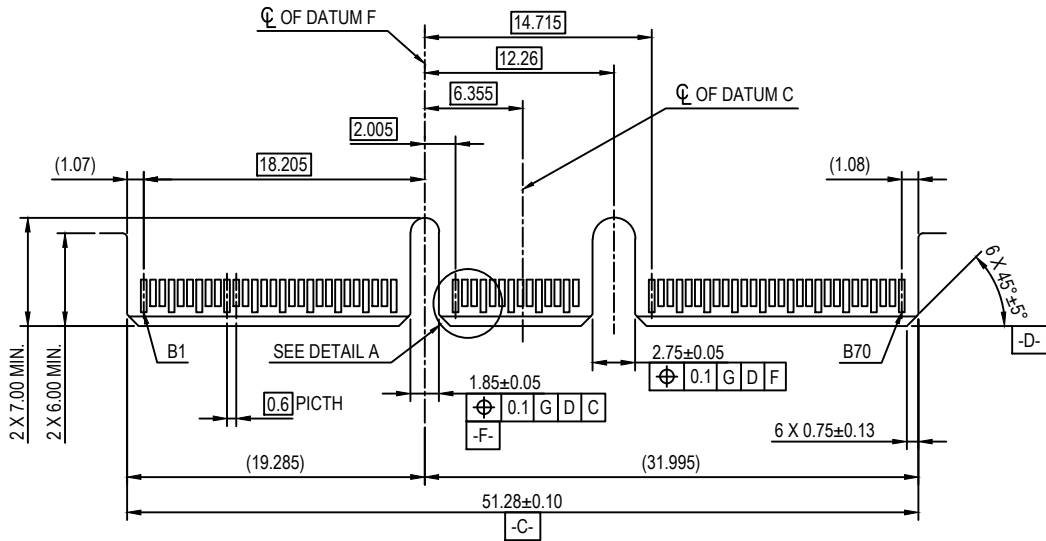

DETAIL A
SCALE 8:1

NOTE: 1. POSITION A1 ON OPPOSITE SIDE OF CARD OF B1.
2. DATUM G IS THE PCB SOLDER SURFACE.

RECOMMENDED EDGE CARD LAYOUT
(BASE ON SFF-TA-1002 SPECIFICATION)

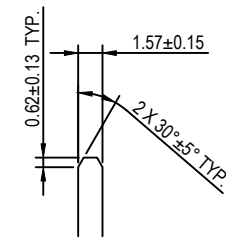
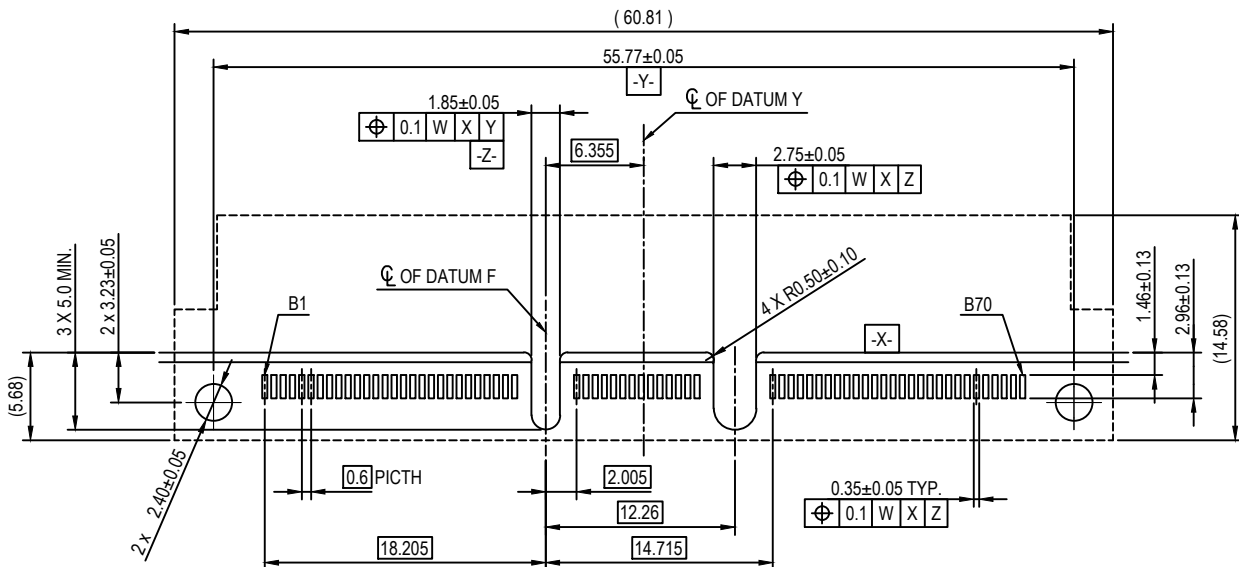

NOTE: 1. POSITION A1 ON OPPOSITE SIDE OF CARD OF B1.
2. DATUM W IS THE PCB SOLDER SURFACE.

RECOMMENDED HOST BOARD LAYOUT
(BASE ON SFF-TA-1002 SPECIFICATION)

QUALITY SYMBOLS	DRAWN BY	DATE	ACES ELECTRONICS
MAJOR	Tseng, Chia Hsien	18/12/05	
CRITICAL	CHECKED BY	DATE	TITLE
GENERAL TOLERANCES (UNLESS SPECIFIED)	Lin, Li Shan	18/12/05	0.6mm PITCH EDGE CARD CONN.
	APPROVED BY	DATE	STRADDLE D/R S/T TYPE.
	Chen, Po Tsang	18/12/05	UNITS
			mm
			SCALE
			2 : 1
			SHEET NO.
			2 OF 3
			SIZE
			A4
			REV
			RFO NO.
			N/A
			DWG NO.
			52725-140XX-001



CONNECTOR CONTACT IDENTIFICATION

CONTACT NUMBER	SIDE A	SIDE B
1	GROUND	GROUND
2	SIGNAL	SIGNAL
3	SIGNAL	SIGNAL
4	GROUND	GROUND
5	SIGNAL	SIGNAL
6	SIGNAL	SIGNAL
7	GROUND	GROUND
8	SIGNAL	SIGNAL
9	SIGNAL	SIGNAL
10	GROUND	GROUND
11	SIGNAL	SIGNAL
12	SIGNAL	SIGNAL
13	GROUND	GROUND
14	SIGNAL	SIGNAL
15	SIGNAL	SIGNAL
16	GROUND	GROUND
17	SIGNAL	SIGNAL
18	SIGNAL	SIGNAL
19	GROUND	GROUND
20	SIGNAL	SIGNAL
21	SIGNAL	SIGNAL
22	GROUND	GROUND
23	SIGNAL	SIGNAL
24	SIGNAL	SIGNAL
25	GROUND	GROUND
26	SIGNAL	SIGNAL
27	SIGNAL	SIGNAL
28	GROUND	GROUND

CONTACT NUMBER	SIDE A	SIDE B
29	GROUND	GROUND
30	SIGNAL	SIGNAL
31	SIGNAL	SIGNAL
32	GROUND	GROUND
33	SIGNAL	SIGNAL
34	SIGNAL	SIGNAL
35	GROUND	GROUND
36	SIGNAL	SIGNAL
37	SIGNAL	SIGNAL
38	GROUND	GROUND
39	SIGNAL	SIGNAL
40	SIGNAL	SIGNAL
41	GROUND	GROUND
42	GROUND	GROUND

CONTACT NUMBER	SIDE A	SIDE B
43	GROUND	GROUND
44	SIGNAL	SIGNAL
45	SIGNAL	SIGNAL
46	GROUND	GROUND
47	SIGNAL	SIGNAL
48	SIGNAL	SIGNAL
49	GROUND	GROUND
50	SIGNAL	SIGNAL
51	SIGNAL	SIGNAL
52	GROUND	GROUND
53	SIGNAL	SIGNAL
54	SIGNAL	SIGNAL
55	GROUND	GROUND
56	SIGNAL	SIGNAL
57	SIGNAL	SIGNAL
58	GROUND	GROUND
59	SIGNAL	SIGNAL
60	SIGNAL	SIGNAL
61	GROUND	GROUND
62	SIGNAL	SIGNAL
63	SIGNAL	SIGNAL
64	GROUND	GROUND
65	SIGNAL	SIGNAL
66	SIGNAL	SIGNAL
67	GROUND	GROUND
68	SIGNAL	SIGNAL
69	SIGNAL	SIGNAL
70	GROUND	GROUND

QUALITY SYMBOLS MAJOR CRITICAL	DRAWN BY Tseng, Chia Hsien	DATE 18/12/05	
	CHECKED BY Lin, Li Shan	DATE 18/12/05	
GENERAL TOLERANCES (UNLESS SPECIFIED) X. ±0.5 .X ±0.25 .XX ±0.15 .XXX ±0.1 ANGLES ±2°	APPROVED BY Chen, Po Tsang	DATE 18/12/05	RFQ NO. N/A
UNITS mm		SIZE A4	DWG NO. 52725-140XX-001
SCALE 2 : 1	SHEET NO. 3 OF 3	REV	