

P/N LEGEND

51988-XXX X X -XXX

NO OF CKT
008:8PIN

XXX	Housing Color
001	Black

PACKING

0:TAPE & REEL
7:TAPE & REEL WITH COVER

PLATING

1:GOLD PLATED ON CONTACT AND SOLDER AREA

NOTES:

1. MATERIAL:

- 1.1 HOUSING: THERMOPLASTIC, HIGH TEMP., UL94V-0; COLOR:BLACK.
- 1.2 CONTACT: COPPER ALLOY
- 1.3 FITTING NAIL : COPPER ALLOY

2. FINISH:

- 2.1 CONTACT:
1: GOLD PLATED ON CONTACT AND SOLDER AREA
50~100u" MIN NICKEL UNDERPLATING OVERALL
- 2.2 FITTING NAIL:
80~150u"MIN TIN PLATING OVERALL,
50~100u" MIN NICKEL UNDERPLATING OVERALL

3. REFLOW SOLDER CAPABLE TO 260°C
PER ACES SPEC.

4. WAVE SOLDER CAPABLE TO 260°C
PER ACES SPEC.

5. SPEC. PLS. REFER TO PS-50975-xxxxx-xxx

6. PACKAGE PLS. REFER TO 51988-xxxxx-xx-TRP

7. PART NUMBER

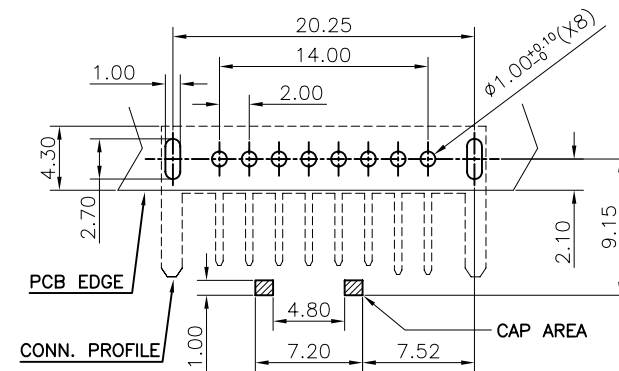
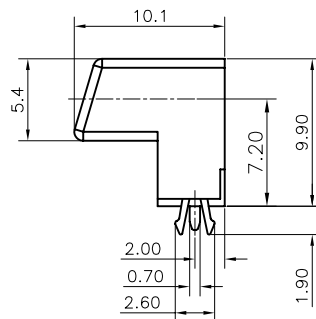
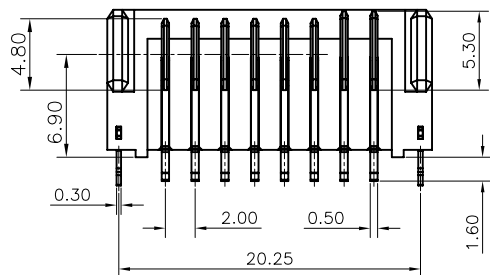

RECOMMENDED PCB LAYOUT
GENERAL TOLERANCE ±0.05

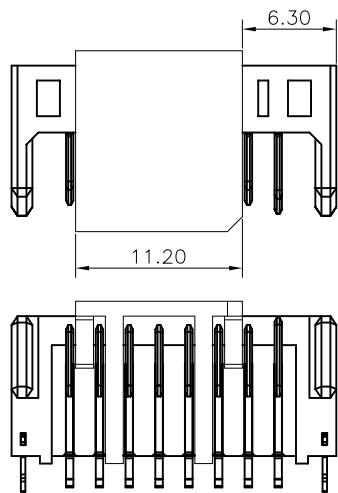

WITH COVER

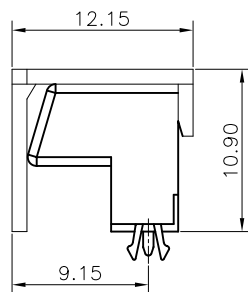

一般公差 TOLERANCES X ±0.50 .XX ±0.15 X ±0.25 .XXX ±0.10 ANGLES ±2°		宏致電子股份有限公司 Aces Electronic Co.,Ltd.	
檢驗尺寸標示 SYMBOLS (M) (L) INDICATE CLASSIFICATION DIMENSION (M) MARK IS CRITICAL DIM. (L) MARK IS MAJOR DIM.	品名 (TITLE) 2.00mm Battery Conn. Male DIP R/A Type H=9.90 圖號 (DWG.NO) 51988-XXXXX-XXX	製圖 (DR) 10/21/11' Brave	審核 (CHKD) Sam
表面處理 (FINISH)	比例 (SCALE) 2:1	單位 (UNITS) mm	核准 (APPD) Jason
			張數 (SHEET) 1 OF 1
			尺寸 (SIZE) A4
			版次 (REV) 0