

(含) 以下一個沉臺,
以上兩個沉臺

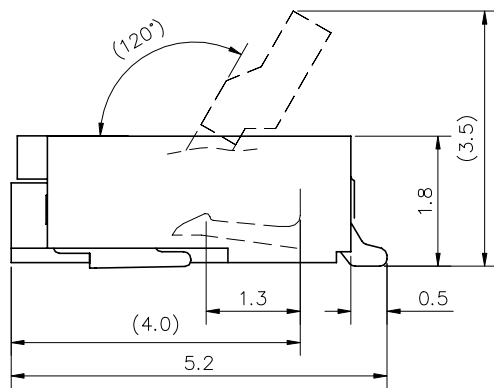

SCALE 6:1

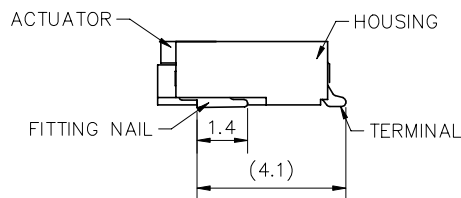
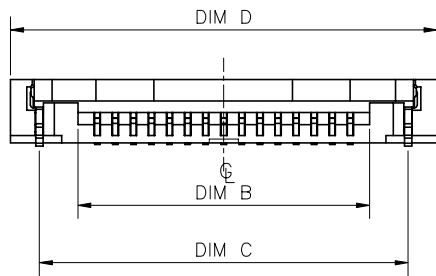

NOTES:

1. MATERIAL:

- 1.1 HOUSING: THERMOPLASTIC, HIGH TEMP.,UL94V-0.
- 1.2 ACTUATOR: THERMOPLASTIC, HIGH TEMP.,UL94V-0.
- 1.3 CONTACT: COPPER ALLOY
- 1.4 FITTING NAIL: COPPER ALLOY

2. FINISH:

2.1 CONTACT:

- 50~100u" NICKEL UNDERPLATING OVERALL.
- 1: GOLD FLASH ON CONTACT AREA
- W: 1u" GOLD ON CONTACT AREA
- M: 3u" GOLD ON CONTACT AREA
- T: 10u" GOLD ON CONTACT AREA
- C: 15u" GOLD ON CONTACT AREA
- K: 30u" GOLD ON CONTACT AREA

2.2 FITTING NAIL:

- 100~200u" MATT TIN PLATING ON SOLDER TAILS(LEAD FREE).
- 50~100u" NICKEL UNDERPLATING OVERALL.

3. REFLOW SOLDER CAPABLE TO 260°C PER ACES SPEC.

4. SPEC. PLS. REFER TO PS-51503-XXXXX

5. PACKAGE PLS. REFER TO 51540-XXXX-XX-TRP

6. PART NUMBER

51540-XXX X X-XXX

NO OF CKT

PACKING

PLATING

- 0: TAPE & REEL
- 4: TAPE & REEL WITH MYLAR
- A: TAPE & REEL (13" PLASTIC)
- B: TAPE & REEL WITH MYLAR (13" PLASTIC)

XXX	HOUSING MATERIAL&COLOR	ACTUATOR MATERIAL&COLOR
001	HF & BLACK	HF & BLACK
002	HF & BLACK	HF & NATURAL
003	HF & NATURAL	HF & NATURAL
005	HF & NATURAL	HF & BLACK

- 1: G/F ON CONTACT AREA
- W: 1u" GOLD ON CONTACT
- M: 3u" GOLD ON CONTACT
- T: 10u" GOLD ON CONTACT
- C: 15u" GOLD ON CONTACT
- K: 30u" GOLD ON CONTACT

QUALITY SYMBOLS MAJOR Ⓜ CRITICAL Ⓢ GENERAL TOLERANCES (UNLESS SPECIFIED) X ±0.5 XX ±0.25 XXX ±0.15 .XXX ±0.1 ANGLES ±2°	DRAWN BY Tsai, Wang Kun 23/08/31	DATE 23/08/31	
	CHECKED BY Wang, Kai Hung 23/08/31	DATE 23/08/31	
	APPROVED BY Huang, Kuo Hua 23/08/31	DATE 23/08/31	RFG NO. N/A
UNITS mm		SIZE A4	DWG NO. 51540-XXXX-XXX
SCALE 3:1	SHEET NO. 1 OF 2	REV L	

A B C D E F G H I J

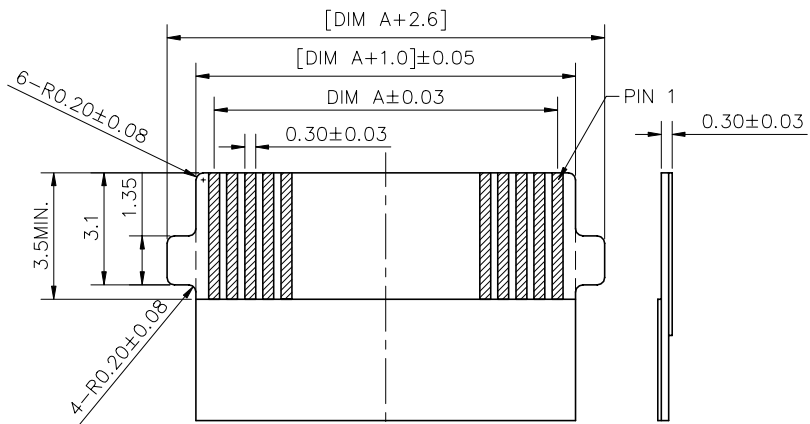

RECOMMENDED FPC/FFC DIMENSIONS
GENERAL TOLERANCE ±0.1

CKT	DIM A	DIM B	DIM C	DIM D	DIM E	M/SIZE	CKT	DIM A	DIM B	DIM C	DIM D	DIM E	M/SIZE
4	1.5	2.57	4.7	6.3	4.1	6.0	33	16.0	17.07	19.2	20.8	18.6	10.0
5	2.0	3.07	5.2	6.8	4.6	6.0	34	16.5	17.57	19.7	21.3	19.1	10.0
6	2.5	3.57	5.7	7.3	5.1	6.0	35	17.0	18.07	20.2	21.8	19.6	10.0
7	3.0	4.07	6.2	7.8	5.6	6.0	36	17.5	18.57	20.7	22.3	20.1	10.0
8	3.5	4.57	6.7	8.3	6.1	6.0	37	18.0	19.07	21.2	22.8	20.6	10.0
9	4.0	5.07	7.2	8.8	6.6	6.0	38	18.5	19.57	21.7	23.3	21.1	10.0
10	4.5	5.57	7.7	9.3	7.1	6.0	39	19.0	20.07	22.2	23.8	21.6	10.0
11	5.0	6.07	8.2	9.8	7.6	6.0	40	19.5	20.57	22.7	24.3	22.1	10.0
12	5.5	6.57	8.7	10.3	8.1	6.0	41	20.0	21.07	23.2	24.8	22.6	10.0
13	6.0	7.07	9.2	10.8	8.6	6.0	42	20.5	21.57	23.7	25.3	23.1	10.0
14	6.5	7.57	9.7	11.3	9.1	6.0	43	21.0	22.07	24.2	25.8	23.6	10.0
15	7.0	8.07	10.2	11.8	9.6	6.0	44	21.5	22.57	24.7	26.3	24.1	10.0
16	7.5	8.57	10.7	12.3	10.1	6.0	45	22.0	23.07	25.2	26.8	24.6	10.0
17	8.0	9.07	11.2	12.8	10.6	6.0	46	22.5	23.57	25.7	27.3	25.1	10.0
18	8.5	9.57	11.7	13.3	11.1	6.0	47	23.0	24.07	26.2	27.8	25.6	10.0
19	9.0	10.07	12.2	13.8	11.6	6.0	48	23.5	24.57	26.7	28.3	26.1	10.0
20	9.5	10.57	12.7	14.3	12.1	6.0	49	24.0	25.07	27.2	28.8	26.6	10.0
21	10.0	11.07	13.2	14.8	12.6	6.0	50	24.5	25.57	27.7	29.3	27.1	10.0
22	10.5	11.57	13.7	15.3	13.1	6.0	51	25.0	26.07	28.2	29.8	27.6	10.0
23	11.0	12.07	14.2	15.8	13.6	6.0	52	25.5	26.57	28.7	30.3	28.1	10.0
24	11.5	12.57	14.7	16.3	14.1	6.0	53	26.0	27.07	29.2	30.8	28.6	10.0
25	12.0	13.07	15.2	16.8	14.6	6.0	54	26.5	27.57	29.7	31.3	29.1	10.0
26	12.5	13.57	15.7	17.3	15.1	6.0	55	27.0	28.07	30.2	31.8	29.6	10.0
27	13.0	14.07	16.2	17.8	15.6	6.0	56	27.5	28.57	30.7	32.3	30.1	10.0
28	13.5	14.57	16.7	18.3	16.1	6.0	57	28.0	29.07	31.2	32.8	30.6	10.0
29	14.0	15.07	17.2	18.8	16.6	6.0	58	28.5	29.57	31.7	33.3	31.1	10.0
30	14.5	15.57	17.7	19.3	17.1	6.0	59	29.0	30.07	32.2	33.8	31.6	10.0
31	15.0	16.07	18.2	19.8	17.6	10.0	60	29.5	30.57	32.7	34.3	32.1	10.0
32	15.5	16.57	18.7	20.3	18.1	10.0							

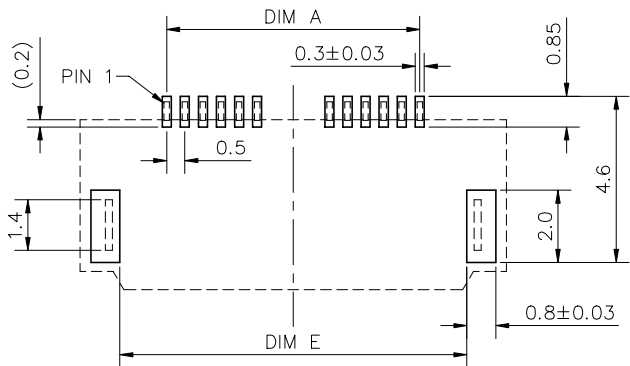

RECOMMENDED PCB LAYOUT
GENERAL TOLERANCE ±0.05

QUALITY SYMBOLS MAJOR Ⓢ CRITICAL Ⓢ GENERAL TOLERANCES (UNLESS SPECIFIED) X. ±0.5 X ±0.25 .XX ±0.15 .XXX ±0.1 ANGLES ±2°	DRAWN BY Tsai, Wang Kun	DATE 23/08/31	
	CHECKED BY Wang, Kai Hung	DATE 23/08/31	
	APPROVED BY Huang, Kuo Hua	DATE 23/08/31	RFG NO. N/A
	UNITS mm		SIZE A4
	SCALE 3 : 1	SHEET NO. 2 OF 2	DWG NO. 51540-XXXXX-XXX

B C D E F G H I J