

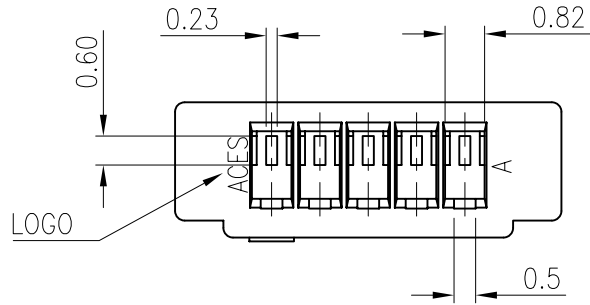

NOTES:

- 材質: Halogen Free PLASTIC, HIGH TEMP UL 94V-0
- Product Spec refer to PS-50224-xxxxx-xxx



P/N LEGEND

50233-XXX H X X X-XXX

NO OF CKT

POLARIZATION
0.NONE

MATERIAL
H.NYLON 66

XXX	Halogen Free	NOTES
001	HF	NA
003	HF	FOR ECOVACS

COLOR
0.WHITE
1.BLACK

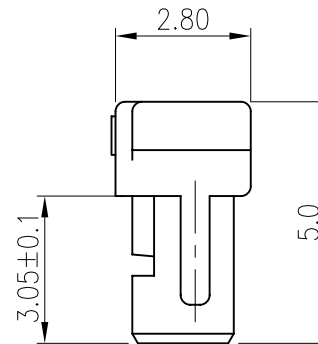
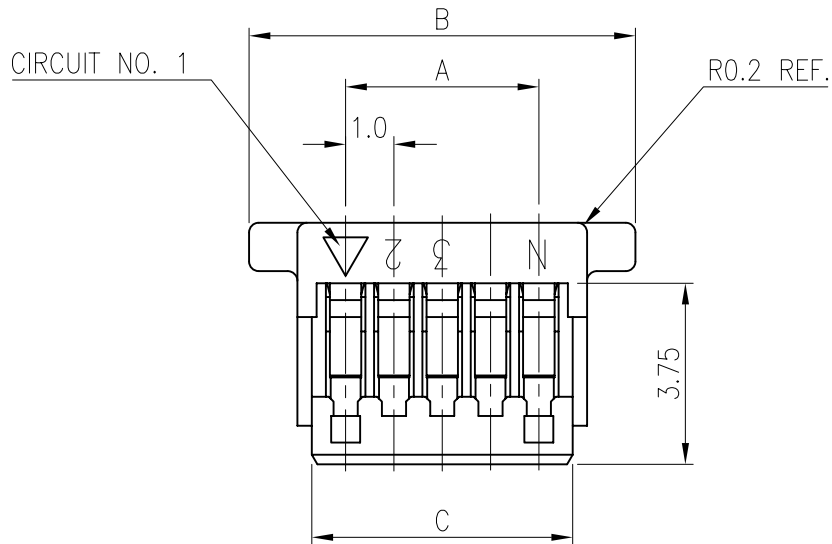

CKT	Dim A	Dim B	Dim C
2	1.0	5.0	2.4
3	2.0	6.0	3.4
4	3.0	7.0	4.4
5	4.0	8.0	5.4
6	5.0	9.0	6.4
7	6.0	10.0	7.4
8	7.0	11.0	8.4
9	8.0	12.0	9.4
10	9.0	13.0	10.4
11	10.0	14.0	11.4
12	11.0	15.0	12.4
13	12.0	16.0	13.4
14	13.0	17.0	14.4
15	14.0	18.0	15.4
16	15.0	19.0	16.4
17	16.0	20.0	17.4
18	17.0	21.0	18.4
19	18.0	22.0	19.4
20	19.0	23.0	20.4
22	21.0	25.0	22.4
24	23.0	27.0	24.4
26	25.0	29.0	26.4
30	29.0	33.0	30.4

QUALITY SYMBOLS MAJOR Ⓢ CRITICAL Ⓢ	DRAWN BY ZHOUQUAN	DATE 18/01/04	
	CHECKED BY BRAVE	DATE 18/01/04	
GENERAL TOLERANCES (UNLESS SPECIFIED) X. ±0.5 .X ±0.25 .XX ±0.15 .XXX ±0.1 ANGLES ±2°	APPROVED BY BRAVE	DATE 18/01/04	TITLE 50233-XXXHXXX-XXX
	UNITS mm		SIZE A4
SCALE 2:1	SHEET NO. 1 OF 1	REV D	PART NO. SEE NOTES