

RECOMMENDED PCB LAYOUT  
GENERAL TOLERANCE ±0.05

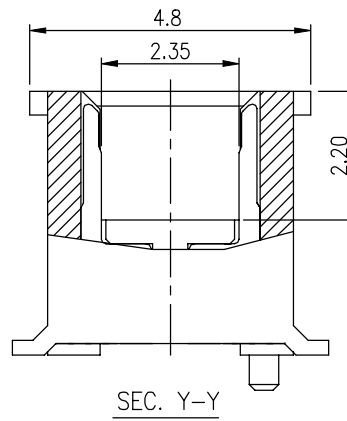
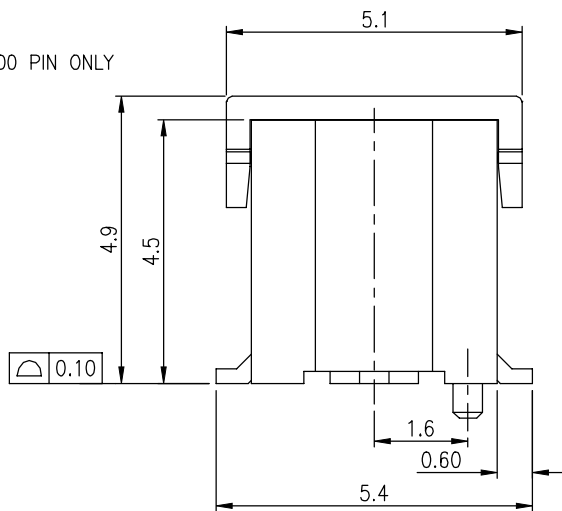
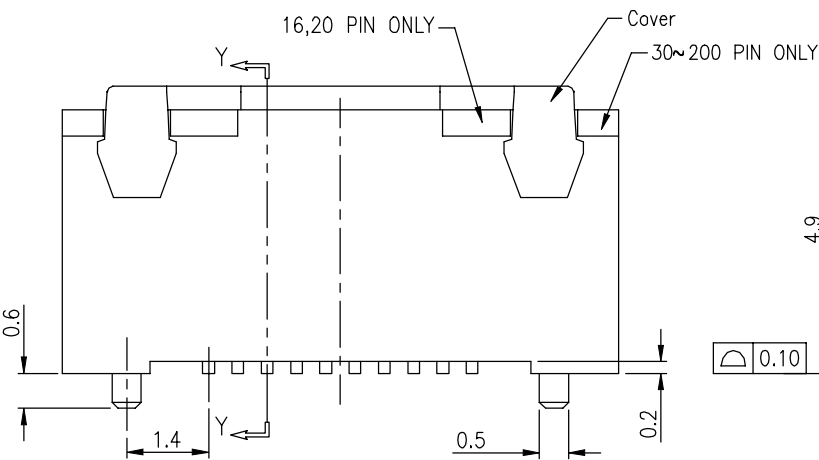

CKT	DIM A	DIM B	DIM C
16	3.5	5.5	8.5
20	4.5	6.5	9.5
30	7.0	9.0	12.0
40	9.5	11.5	14.5
50	12.0	14.0	17.0
60	14.5	16.5	19.5
70	17.0	19.0	22.0
80	19.5	21.5	24.5
100	24.5	26.5	29.5
120	29.5	31.5	34.5
160	39.5	41.5	44.5
180	44.5	46.5	49.5
200	49.5	51.5	54.5

NOTES:

- MATERIAL:
  - HOUSING: THERMOPLASTIC, HIGH TEMP., UL94V-0;
  - CONTACT: COPPER ALLOY
  - FITTING NAIL: COPPER ALLOY
- FINISH:
  - CONTACT:
    - 50~100μ" NICKEL UNDERPLATING OVERALL.
    - 1: GOLD FLASH ON CONTACT AND SOLDER AREA.
    - C: 15U" GOLD ON CONTACT AREA, GOLD FLASH ON SOLDER AREA.
  - FITTING NAIL:
    - 50~100μ" NICKEL UNDERPLATING OVERALL.
    - GOLD FLASH UNDERPLATING NICKEL
- IR REFLOW CAPABLE TO 260°C PER ACES SPEC.
- SPEC. PLS. REFER TO PS-50022-xxxxx-xxx
- PACKAGE PLS. REFER TO 88495-XXXX-TRP
- PART NUMBER

50022-XXX X X-XXX

No Of Contact

XXX	Housing Color	Halogen Free
001	Black	<b>HF</b>

PACKING

- 0:TAPE&REEL
- 7:TAPE&REEL WITH COVER
- 8:TUBE WITH COVER

PLATING

- 1:GOLD FLASH
- C:15U" GOLD ON CONTACT

<b>QUALITY SYMBOLS</b> MAJOR Ⓢ CRITICAL Ⓢ <b>GENERAL TOLERANCES (UNLESS SPECIFIED)</b> X. ±0.5 .X ±0.25 .XX ±0.15 .XXX ±0.1 ANGLES ±2°	DRAWN BY Hu, Shul Hong DATE 21/08/18		
	CHECKED BY Lu, ling Quan DATE 21/08/18		TITLE 0.5mm BTB PLUG SMT D/R/S/T TYPE
APPROVED BY hsieh, fu yu DATE 21/08/18	UNITS mm	SIZE A4	RFQ NO. N/A
	SCALE 8 : 1	SHEET NO. 1 OF 1	REV C