

ROHS

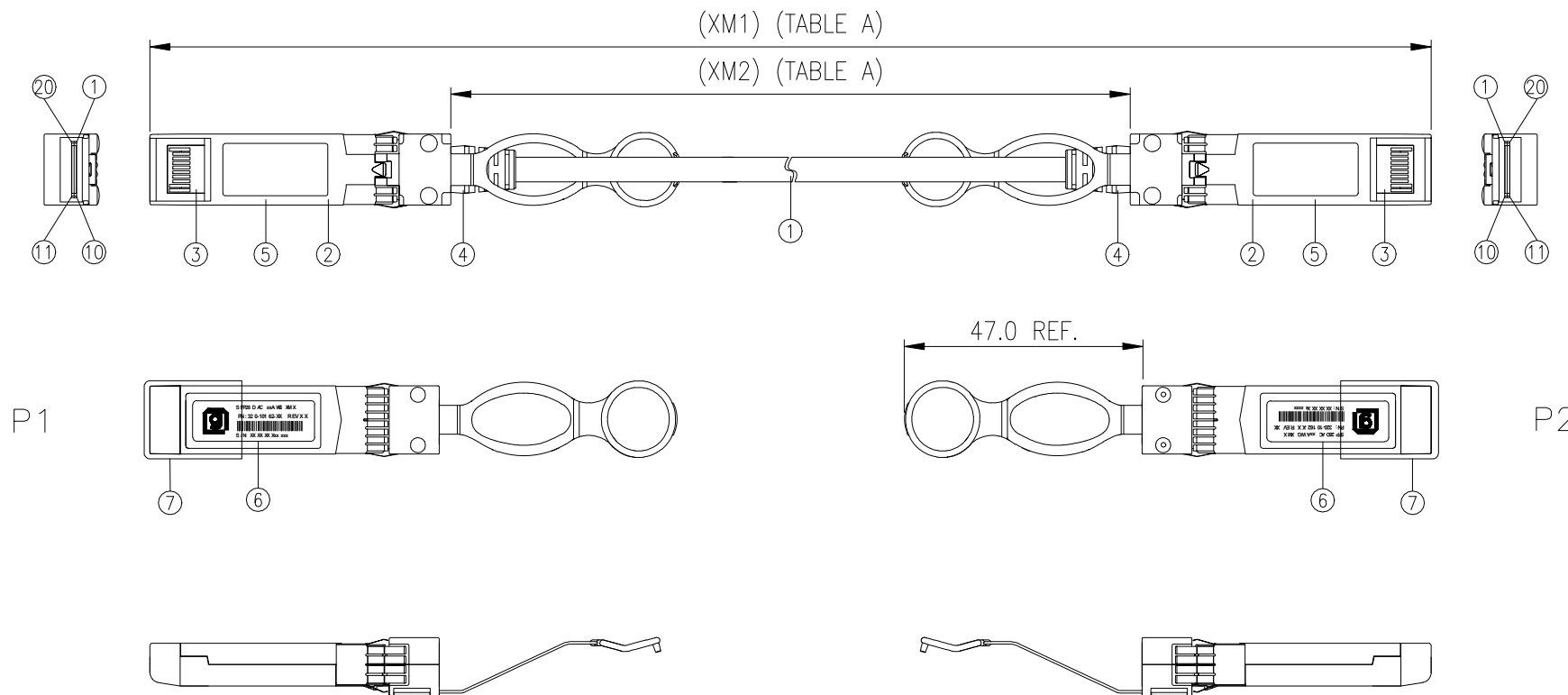

NOTE(注释):

- CABLE ASSEMBLY IMPEDANCE:** 100±10 ohm.
成品特性阻抗: 100±10 欧姆
- 100% CONDUCTOR TEST, TEST CONDITION:** VOLTAGE 5V, INSULATION RESISTANCE 10M ohm, CONDUCTION RESISTANCE MAX 3 ohm
100% 导通测试, 测试条件为电压5V, 绝缘10M欧姆, 导通电阻不大于3欧姆
- HIGH-FREQUENCY TEST ACCORDING TO IEEE 802.3 STANDARD.**
高频测试依照IEEE802.3标准测试
- ALL MATERIAL MUST COMPLY WITH ROHS2.0.**
所有物料必须符合ROHS2.0
- PROGRAM PER EEPROM 777-10017-XX**

7	DUST COVER	2	DUST COVER FOR SFP, PE, NATURAL	
6	SHELL	2	SHELL BARCODE LABELS	
5	MOLDING	2	INNER MOLDING FOR SFP	
4	STRAIN RELIEF	2	CABLE SR FOR SFP	
3	PCB	2	SFP PCB	
2	CONNECTOR	2	SFP CONNECTOR	
1	CABLE	A/R	TABLE A, WIRE TYPE, WIRE GAUGE	
ITEM	NAME	Q'TY	DESCRIPTION	NOTE

B	Add wire winding size.	05-25-22'	Liuziming
A	Initial issue.	04-19-22'	Liuziming
Rev.	Revision Description	Date	Prepared
QUALITY SYMBOLS MAJOR (M) CRITICAL (C) GENERAL TOLERANCES (UNLESS SPECIFIED) X. ±0.5 .X ±0.25 .XX ±0.1 .XXX ±0.05 ANGLES ±2°	DRAWN BY Liuziming CHECKED BY APPROVED BY DATE 2022/05/25 DATE DATE	ACES ELECTRONICS TITLE SFP28 TO SFP28,25G,DAC	
UNITS mm SCALE NONE	SHEET NO. 10F3	SIZE A4 REV B	RFQ NO. PART NO: 320-10162-XX PART NO. 61-6425-XXX-FA

A B C D E F G H I J

1

2

3

4

5

6

7

1

2

3

4

5

6

7

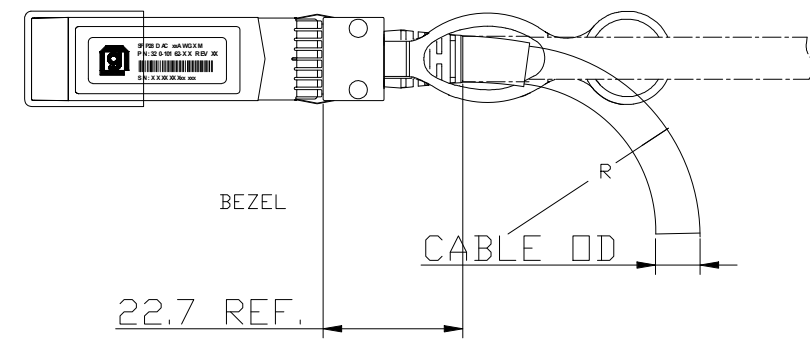
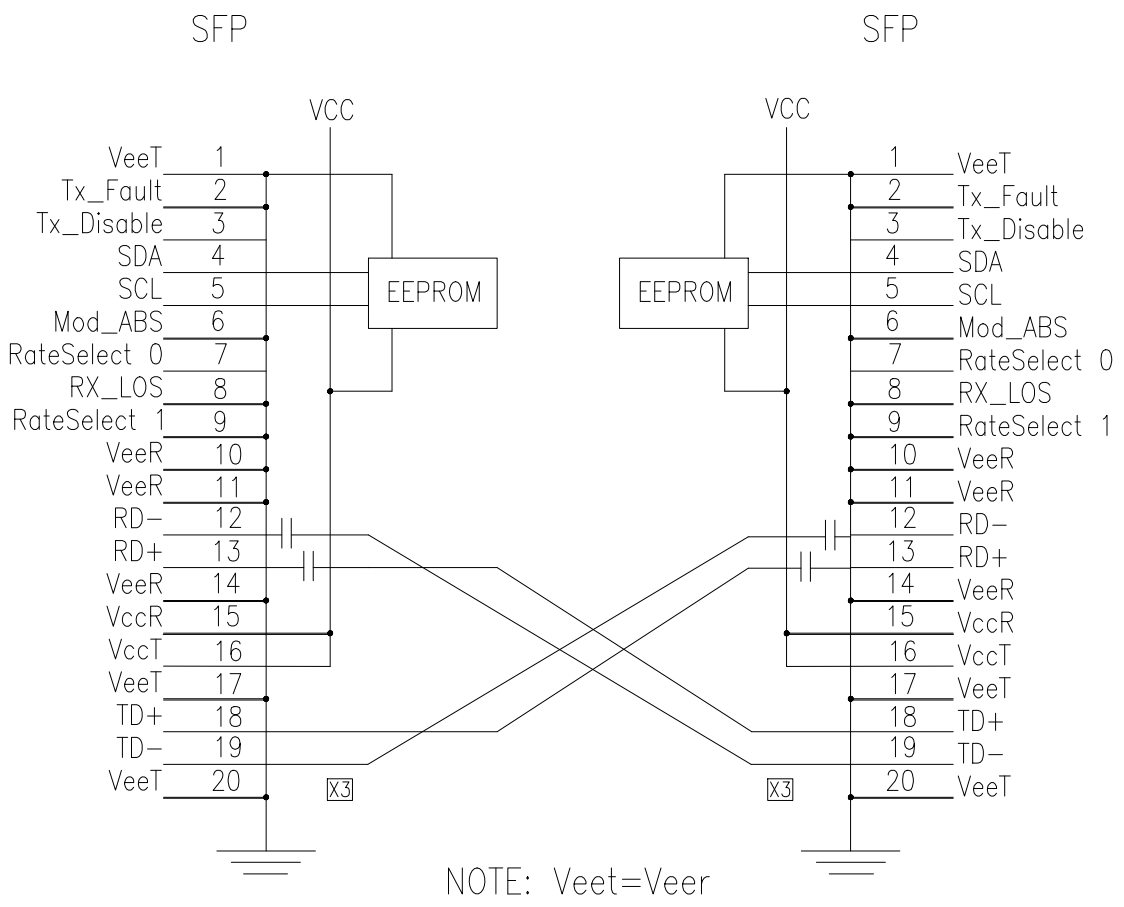

CABLE GAUGE	CABLE "OD"	STATIC BEND RADIUS"R"	DYNAMIC BEND RADIUS"R"
30AWG	4.5MM	22.5MM	45MM
26AWG	5.1MM	25.5MM	51MM

B	Add wire winding size.	05-25-22'	Liuziming
A	Initial issue.	04-19-22'	Liuziming
Rev.	Revision Description	Date	Prepared
QUALITY SYMBOLS MAJOR Ⓜ CRITICAL Ⓢ GENERAL TOLERANCES (UNLESS SPECIFIED) X. ±0.5 .X ±0.25 .XX ±0.1 .XXX ±0.05 ANGLES ±2°		DRAWN BY Liuziming DATE 2022/05/25 CHECKED BY DATE APPROVED BY DATE	ACES ELECTRONICS TITLE SFP28 TO SFP28,25G,DAC SIZE A4 UNITS mm SCALE NONE SHEET NO. 20F3 REV B
		RFQ NO.	
		PART NO:	320-10162-XX
		PART NO.	61-6425-XXX-FA

A B C D E F G H I J

CONN. LABEL(壳标):

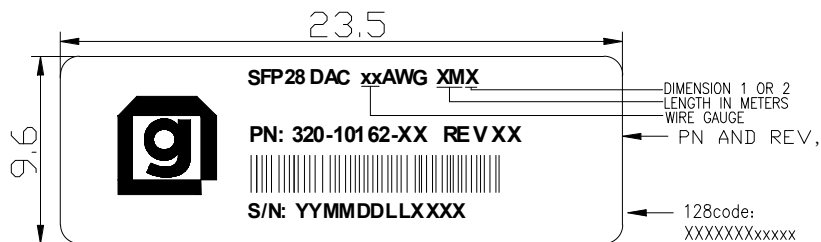

S/N: YYMMDDLXxxx
 SERIAL NO
 YEAR, MONTH,
 DAY, LOCATION

PACKAGING:

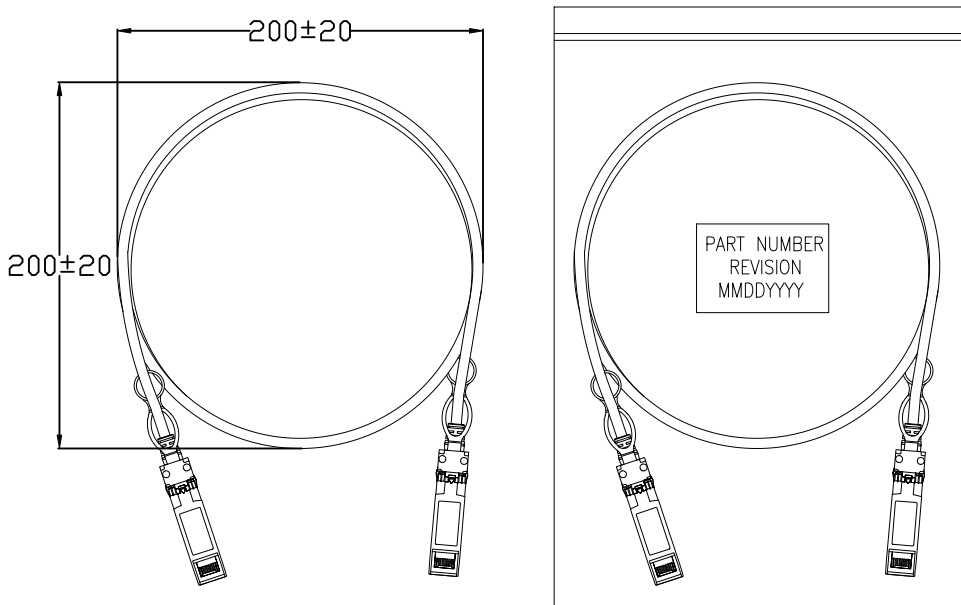

MEC P/N	PART NUMBER	WIRE TYPE	xx AWG	XM1 LENGTH	XM2 LENGTH
	320-10162-01	PVC	30	500±20	
	320-10162-02	PVC	30	1000±30	
	320-10162-03	PVC	30	1500±30	
	320-10162-04	PVC	30	2000±30	
	320-10162-05	PVC	30	2500±30	
	320-10162-06	PVC	26	2500±30	
▲ 61-6425-830-FA	320-10162-07	PVC	30	3000±40	
	320-10162-08	PVC	26	3000±40	
	320-10162-09	PVC	26	5000±50	
	320-10162-19	PVC	30		500±20
	320-10162-20	PVC	30		1000±30
	320-10162-21	PVC	30		1500±30
	320-10162-22	PVC	30		2000±30
	320-10162-23	PVC	30		2500±30
	320-10162-24	PVC	26		2500±30
	320-10162-25	PVC	30		3000±40
	320-10162-26	PVC	26		3000±40
	320-10162-27	PVC	26		5000±50

B	Add wire winding size.	05-25-22'	Liuziming
A	Initial issue.	04-19-22'	Liuziming
Rev.	Revision Description	Date	Prepared

QUALITY SYMBOLS MAJOR (M) CRITICAL (C) GENERAL TOLERANCES (UNLESS SPECIFIED) X. ±0.5 .X ±0.25 .XX ±0.1 .XXX ±0.05 ANGLES ±2°	DRAWN BY		DATE				
	Liuziming		2022/05/25				
	CHECKED BY		DATE		TITLE SFP28 TO SFP28,25G,DAC		
	APPROVED BY		DATE				
UNTS		mm		SIZE		RFQ NO.	
SCALE		NONE		SHEET NO.		REV	
		30F3		B		PART NO. 320-10162-XX	
						PART NO. 61-6425-XXX-FA	