

ROHS

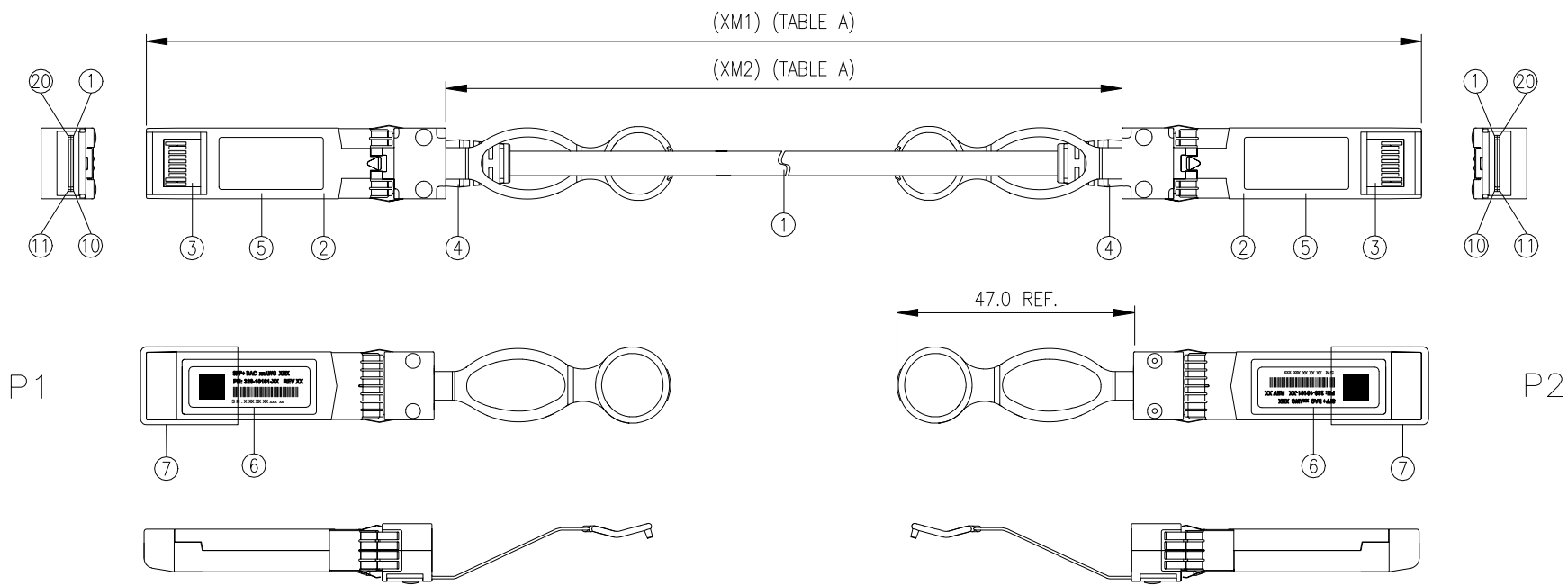

NOTE(注释):

- CABLE ASSEMBLY IMPEDANCE: 100±10 ohm.
成品特性阻抗: 100±10 欧姆
- 100% CONDUCTOR TEST, TEST CONDITION: VOLTAGE 5V, INSULATION RESISTANCE 10M ohm, CONDUCTION RESISTANCE MAX 3 ohm
100% 导通测试, 测试条件为电压5V, 绝缘10M欧姆, 导通电阻不大于3欧姆
- HIGH-FREQUENCY TEST ACCORDING TO IEEE802.3 STANDARD.
高频测试依照IEEE802.3标准测试
- ALL MATERIAL MUST COMPLY WITH ROHS2.0.
所有物料必须符合ROHS2.0
- PROGRAM EEPROM PER 777-10021-XX

7	DUST COVER	2	DUST COVER FOR SFP, PE, NATURAL	
6	SHELL	2	SHELL BARCODE LABELS	
5	MOLDING	2	INNER MOLDING FOR SFP	
4	STRAIN RELIEF	2	CABLE SR FOR SFP	
3	PCB	2	SFP PCB	
2	CONNECTOR	2	SFP CONNECTOR	
1	CABLE	A/R	TABLE A, WIRE TYPE, WIRE GAUGE	
ITEM	NAME	Q'TY	DESCRIPTION	NOTE

B	Add wire winding size.	05-25-22'	Liuziming
A	Initial issue.	04-19-22'	Liuziming
Rev.	Revision Description	Date	Prepared

QUALITY SYMBOLS MAJOR Ⓜ CRITICAL Ⓢ GENERAL TOLERANCES (UNLESS SPECIFIED) .X ±0.5 .XX ±0.25 .XX ±0.1 .XXX ±0.05 ANGLES ±2°	DRAWN BY Liuziming DATE 2022/05/25		TITLE SFP+ASSEMBLY		
	CHECKED BY DATE 				APPROVED BY DATE
	UNITS mm		SIZE A4	RFQ NO.	
	SCALE NONE	SHEET NO. 10F3	REV B	PART NO.: 320-10161-XX	PART NO.: 61-6425-XXX-FA

A B C D E F G H I J

1

2

3

4

5

6

7

1

2

3

4

5

6

7

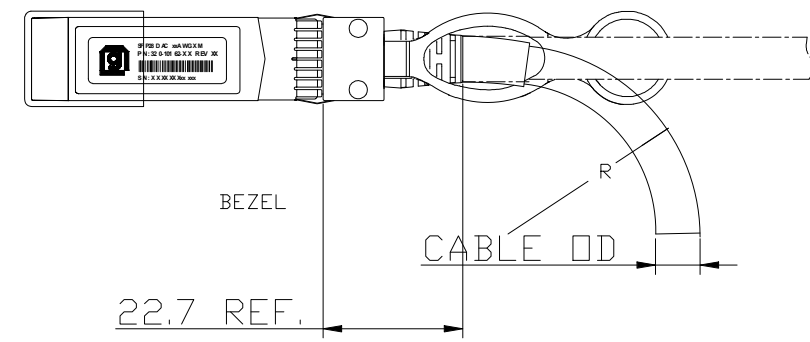
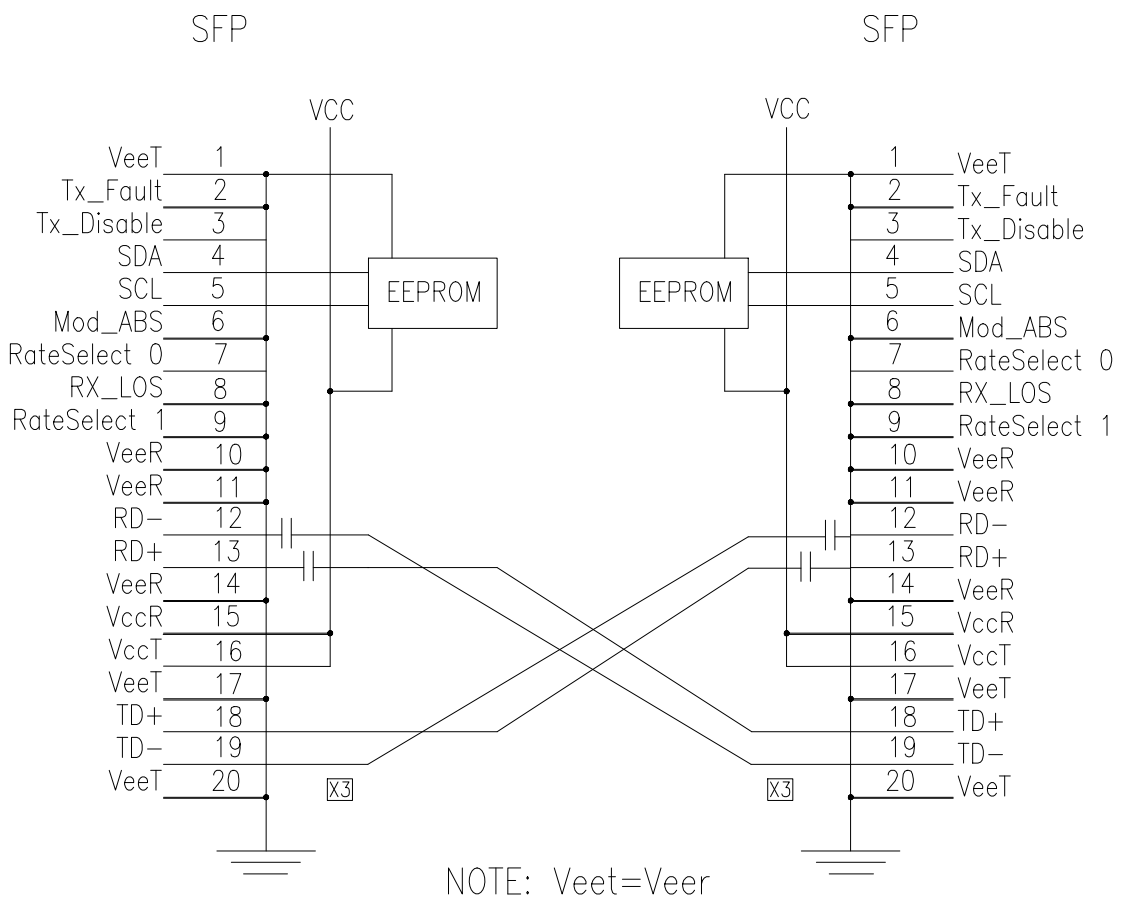

CABLE GAUGE	CABLE "OD"	STATIC BEND RADIUS"R"	DYNAMIC BEND RADIUS"R"
30AWG	4.5MM	22.5MM	45MM
26AWG	5.1MM	25.5MM	51MM

B	Add wire winding size.	05-25-22'	Liuziming
A	Initial issue.	04-19-22'	Liuziming
Rev.	Revision Description	Date	Prepared
QUALITY SYMBOLS MAJOR Ⓜ CRITICAL Ⓢ GENERAL TOLERANCES (UNLESS SPECIFIED) X. ±0.5 .X ±0.25 .XX ±0.1 .XXX ±0.05 ANGLES ±2°		DRAWN BY Liuziming CHECKED BY APPROVED BY UNITS mm SCALE NONE	DATE 2022/05/25 DATE DATE SIZE A4 REV B SHEET NO. 20F3
		ACES ELECTRONICS TITLE SFP28 TO SFP28,25G,DAC	
		RFQ NO.	
		PART NO:	320-10162-XX
		PART NO.	61-6425-XXX-FA

A B C D E F G H I J

CONN. LABEL(壳标):

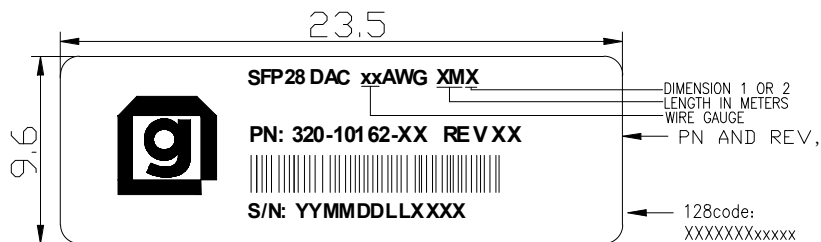

S/N: YYMMDDLXxxx
 SERIAL NO
 YEAR, MONTH,
 DAY, LOCATION

PACKAGING:

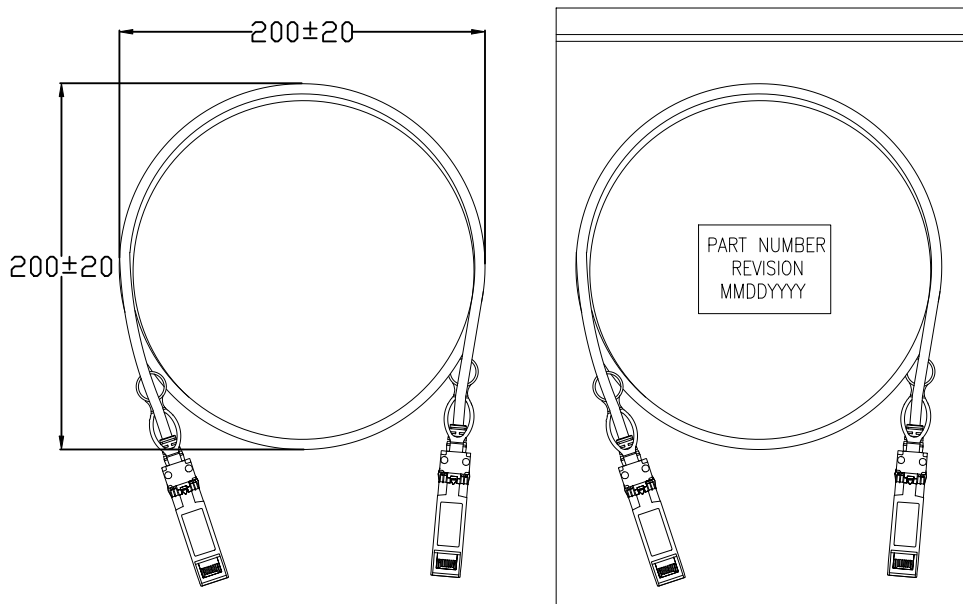

MEC P/N	PART NUMBER	WIRE TYPE	xx AWG	XM1 LENGTH	XM2 LENGTH
	320-10162-01	PVC	30	500±20	
	320-10162-02	PVC	30	1000±30	
	320-10162-03	PVC	30	1500±30	
	320-10162-04	PVC	30	2000±30	
	320-10162-05	PVC	30	2500±30	
	320-10162-06	PVC	26	2500±30	
▲ 61-6425-830-FA	320-10162-07	PVC	30	3000±40	
	320-10162-08	PVC	26	3000±40	
	320-10162-09	PVC	26	5000±50	
	320-10162-19	PVC	30		500±20
	320-10162-20	PVC	30		1000±30
	320-10162-21	PVC	30		1500±30
	320-10162-22	PVC	30		2000±30
	320-10162-23	PVC	30		2500±30
	320-10162-24	PVC	26		2500±30
	320-10162-25	PVC	30		3000±40
	320-10162-26	PVC	26		3000±40
	320-10162-27	PVC	26		5000±50

B	Add wire winding size.	05-25-22'	Liuziming
A	Initial issue.	04-19-22'	Liuziming
Rev.	Revision Description	Date	Prepared

QUALITY SYMBOLS MAJOR (M) CRITICAL (C) GENERAL TOLERANCES (UNLESS SPECIFIED) X. ±0.5 .X ±0.25 .XX ±0.1 .XXX ±0.05 ANGLES ±2°	DRAWN BY		DATE		
	Liuziming		2022/05/25		
	CHECKED BY		DATE		
	APPROVED BY		DATE		
TITLE				SFP28 TO SFP28,25G,DAC	
UNTS		SIZE		RFQ NO.	
mm		A4			
SCALE		SHEET NO.		REV	
NONE		30F3		B	
				PART NO. 320-10162-XX	
				PART NO. 61-6425-XXX-FA	