

PROPRIETARY INFORMATION  
COMPANY CONFIDENTIAL

REV.	ECN. NO.	DESCRIPTION	ENG	DATE
A		INITIAL	Hill	05/21/21"
B		ADD PLATING OPTION	Hill	06/03/21"
C		ADD 6U" PLATING	Hill	07/01/21"

**NOTES:**

**ELECTRICAL:**

1. VOLTAGE RATING : 125 VAC RMS.
2. CURRENT RATING : 1.5 AMP.
3. CONTACT RESISTANCE : 30 MILLIOHMS MAX.
4. INSULATION RESISTANCE : 1000 MEGOHMS MIN. @ 500VDC.
5. DIELECTRIC STRENGTH : 1000 VAC RMS 60Hz, 1MIN.

**MECHANICAL:**

1. HOUSING & INSERT MATERIAL : PA9T, UL94V-0, Black
2. CONTACT MATERIAL : C5210-EH, t=0.35mm.
3. PLATING : GOLD PLATING SEE OPTION
4. OPERATING LIFE : 750 CYCLES MIN.
5. PCB RETENTION PRE-SOLDER : 1 LB MIN.
6. PCB RETENTION POST-SOLDER : 10 LBS MIN.

**ENVIRONMENTAL:**

1. STORAGE : -40°C TO +85°C.
2. OPERATION : -40°C TO +85°C.

MATES WITH MODULAR PLUG CONFORMING TO TIA-1096-A.

**C** **B** P/N Description:  
200-10186-0X

- Plating Option  
1=Gold Flashing  
2=15u" Gold  
3=6u" Gold

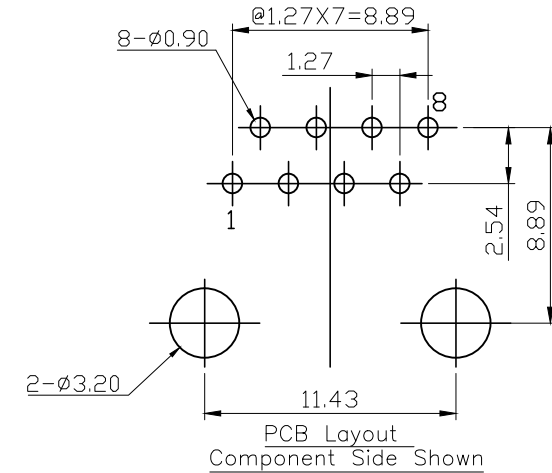
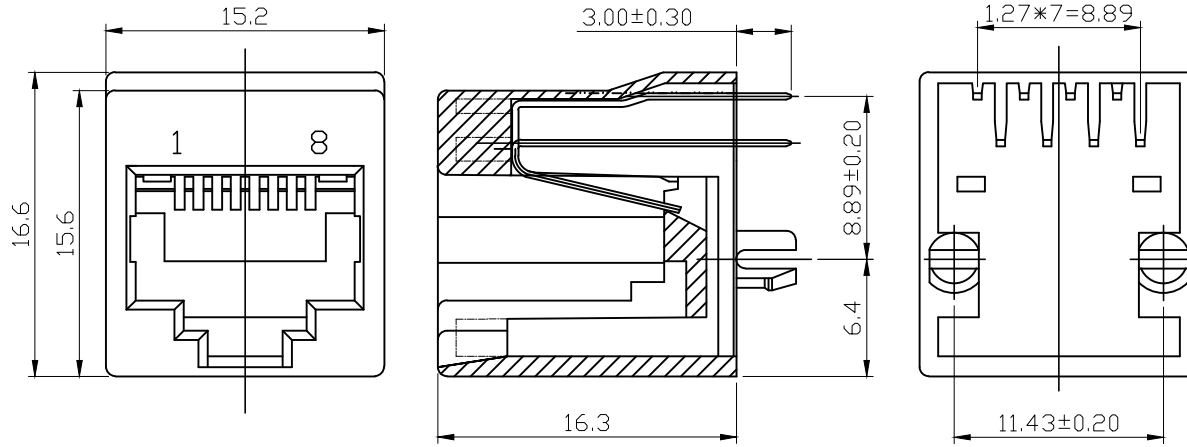

GENERAL TOLERANCE		ANGLE TOLERANCE		DRAWN	DATE	
.X± 0.20	.XX± 0.15	.XXX± 0.10	X± 2.0° .X± 2.0° .XX± .XXX±	Hill	07/01/21"	
MATERIAL <i>SEE BOM</i>				CHECKED	DATE	PART NUMBER. 200-10186-0X
FINISH <i>SEE BOM</i>				APPROVED	DATE	DRAWING NO. 200-10186
SCALE <i>N/A</i>	UNIT <i>mm</i>	SHEET 1 OF 2		Hill	07/01/21"	SIZE <i>A4</i> REV. <i>C</i>